



NS128

Specification for Pole Installation and Removal

DECEMBER 2008

Amendments: NSAs 1529 June 09 & 1604 Mar 11



SUMMARY

Network Standard NS128 describes the requirements relating to the handling, positioning, erection and removal of concrete, steel and wood poles.

ISSUE

Ausgrid staff: for issue to all staff performing work associated with the handling, positioning, erection and removal of concrete, steel and wood poles; and for reference by technical and engineering staff associated with overhead mains and poles.

Where this standard is issued as a controlled document replacing an earlier edition; remove and destroy the superseded document.

Accredited Service Providers: document issued on an uncontrolled basis. Users are responsible for ensuring that the document they are using is current and includes any amendments issued since the date on the document. Ausgrid will not accept any liability for work carried out to a superseded standard. Ausgrid may not accept work carried out which is not in accordance with current standard requirements.

Ausgrid maintains a copy of this and other Network Standards together with updates and amendments on www.ausgrid.com.au.

Ausgrid also offers a subscription service which provides for updates and amendments to standards on payment of an annual fee.

DISCLAIMER

As Ausgrid's standards are subject to ongoing review, the information contained in this document may be amended by Ausgrid at any time.

It is possible that conflict may exist between standard documents. In this event, the most recent standard is to prevail.

This document has been developed using information available from field and other sources and is suitable for most situations encountered in Ausgrid. Particular conditions, projects or localities may require special or different practices. It is the responsibility of the local manager, supervisor, assured quality contractor and the individuals involved to ensure that a safe system of work is employed and that statutory requirements are met.

Ausgrid disclaims any and all liability to any person or persons for any procedure, process or any other thing done or not done, as a result of this Network Standard.

INTERPRETATION

In the event that any user of this Standard considers that any of its provisions is uncertain, ambiguous or otherwise in need of interpretation, the user should request Ausgrid to clarify the provision. Ausgrid's interpretation shall then apply as though it was included in the Standard, and is final and binding. No correspondence will be entered into with any person disputing the meaning of the provision published in the Standard or the accuracy of Ausgrid's interpretation.

Network Standard
NS128
Specification for Pole Installation and Removal
December 2008

CONTENTS

1	INTRODUCTION	1
1.1	General.....	1
1.2	WorkCover - Code of Practice: Work Near Overhead Power Lines	1
2	REFERENCES	3
2.1	Ausgrid Documents.....	3
2.2	Other Standards and Documents	3
2.3	Acts and Regulations	4
3	DEFINITIONS	5
4	RESPONSIBILITIES	6
5	HANDLING PRECAUTIONS.....	7
5.1	Asbestos.....	7
5.2	Handling, Storing or Transporting Poles	7
5.3	Wood Poles	7
5.4	Concrete Poles.....	7
5.5	Steel Poles	7
6	MARKING OF POLES	8
6.1	Wood Poles.....	8
6.2	Concrete Poles.....	8
6.3	Steel Poles	8
7	DISPOSAL OF POLES	9
8	EARTHING	10
9	SINKING OF HOLES	11
9.1	Rock Excavation	11
9.2	Utility Services and Obstructions	11
9.3	Pole Sinking Depths.....	11
10	POLE ERECTION.....	12
10.1	Wood Pole Inspection and Treatment.....	12
10.2	Concrete Pole Inspections and Treatment.....	12
10.3	Steel Pole Inspections and Treatment.....	12
10.4	Erecting Poles or Columns in Proximity to Mains	12
10.5	Raking and Staying of Poles with Unbalanced Loads	13
10.6	Back Filling.....	13
10.7	Footing Strength.....	13
10.8	Baulking.....	14
10.9	Concreting Butt	14
10.10	Vegetation Clearing for New Poles and Lines	14
10.11	Restoration of Surfaces after Installation of Poles	14
10.11.1	Unpaved Areas.....	15
10.11.2	Paved Areas	15
11	REMOVAL OF POLES	16
11.1	General.....	16

11.2	Removal of Pole Butts.....	16
11.3	Removal of Pole Attachments.....	16
11.4	Disposal of Wood Poles with Steel Reinforcing 'Nails' Attached.....	17
11.4.1	Pole Reinforcement.....	17
11.4.2	Reinforced Poles Removed From Service.....	17
11.4.3	Notification of Reinforced Poles Removed.....	17
11.4.4	Storage of Poles with Reinforcing 'Nails' Attached.....	17
11.5	Restoration of Surfaces after Removal of Poles.....	18
11.5.1	Unpaved Areas.....	18
11.5.2	Paved Areas.....	18
12	METHOD OF SECURING CONDEMNED POLES.....	19
13	STORES AND MATERIALS.....	21
APPENDIX A	MATERIAL STOCK CODE NUMBERS.....	22
APPENDIX B	FOOTWAY ALLOCATIONS.....	23
APPENDIX C	CHECKLIST FOR POLES.....	29
APPENDIX D	VEGETATION CLEARANCE REQUIREMENTS.....	30
APPENDIX E	WOOD POLE SPECIFICATION AND ACCEPTANCE PROCEDURES.....	31
E.1	COMMON REQUIREMENTS.....	31
E.1.1	Extent of Specification.....	31
E.1.2	Purpose of Equipment.....	31
E.1.3	Description of Goods.....	31
E.1.4	Average Weights of Poles.....	32
E.1.5	Inspection.....	32
E.1.6	Rejection and Replacement.....	32
E.1.7	Quality Assurance.....	32
E.2	PRESERVATIVE TREATED HARDWOOD POLES.....	33
E.2.1	Drawing Included In Specification.....	33
E.2.2	Materials and Workmanship.....	33
E.2.3	Preservative Treatment.....	36
E.3	UNTREATED FULLY DE-SAPPED HARDWOOD POLES.....	37
E.3.1	Drawing Included In Specification.....	37
E.3.2	Materials and Workmanship.....	37
APPENDIX F	POLE STEPS, PERMANENT ATTACHMENTS AND PREVENTION OF UNAUTHORISED ACCESS.....	39
F.1	GENERAL.....	39
F.2	POLE STEPS.....	39
F.3	Other Permanent Attachments.....	39
APPENDIX G	LASHING CONDEMNED POLES USING POLYPROPYLENE ROPE.....	42
APPENDIX H	"MAKING SAFE" CONDEMNED POLES USING PIKES.....	45

1 INTRODUCTION

1.1 General

In general, Ausgrid uses *CCA treated poles* (*wood poles* that are copper-chrome-arsenate pressure impregnated). They are generally to be installed for supporting circuits which don't have an overhead earthwire.

Generally, transmission and subtransmission circuits will be protected by overhead earthwire and be suitable for the preferred concrete pole construction. However, in some circumstances wood or *steel poles* may be preferable. For these projects the construction type will be specified on an individual basis.

Desapped durable species timber poles were the most common pole used by Ausgrid pre-early 1990's. Almost all timber poles purchased since the early 1990's have been full length CCA pressure impregnated treated. Many *desapped durable species timber poles* can still be found in Ausgrid network but now they are generally only purchased for bushfire areas.

The following precautions must be observed when working with *CCA treated poles*:

- The handling, drilling and cutting of all *CCA treated poles* requires special consideration to ensure that the outer treated surface is not damaged.
- Burning *CCA treated poles* emit toxic arsenic and chromium laden smoke and ash. If you are not required in the area of operations, while burnt or burning material is being handled, stay out of the immediate area and up wind. In general no employee or contractor is to handle or disturb burnt CCA treated material unless:
 - the burnt material must be moved or contained at that time (this may be either for safety reasons or work requirements), and
 - they have received the necessary training, and
 - they have the required personal protective equipment.
- Only appropriately trained workers should disturb CCA treated timber that is burning or has been burnt. However all burnt or partially burnt *CCA treated poles* must be immediately reported to the Ausgrid Supervisor / Contract Officer / Customer Operations Officer to ensure appropriate action is taken (ie containment / removal). For the handling of Burnt and Burning CCA treated timber poles refer to NS145 *Pole Inspection and Treatment Procedures - "Appendix H"*.

Where no distinction has been made between wood, steel or *concrete poles* by a subheading in this standard, the information contained under that heading is common to all types of poles.

The durability class of *wood poles* must be as specified in Section 13.

Wood poles should not be installed in reclaimed land, landfill sites, wetlands or similar locations. Also, note the requirements of NS145, and consider the cost of pole inspection and maintenance when installing poles in difficult locations.

Refer to Section 13 regarding restrictions on timber species used for pole mounted distribution substations and underground to overhead connection poles.

Note: Poles that have been lashed with only one lashing prior to the issue of this Network Standard do not have to have the second lashing added.

1.2 WorkCover - Code of Practice: Work Near Overhead Power Lines

Work on Ausgrid's electricity network assets where the work is carried out in accordance with the requirements of the Electricity Supply (Safety and Network Management) Regulation 2008 and the work is either:

- by or for an electricity network operator, or
- by an *Accredited Service Provider*, or
- by a telecommunications network operator is excluded from this code of practice.

This WorkCover code of practice applies to other work which is carried out near overhead power lines and associated electrical apparatus.

2 REFERENCES

2.1 Ausgrid Documents

Drawings:

- 118306: Overhead Construction 33 kV, 66 kV and 132 kV Spun Concrete Poles. Single Pole Structures Location of Pole Dressing Fixtures.
- 21852: Overhead Construction Pole Cap – Details
- 61501: Overhead Stays & Stay Poles anchorages, Footings & Termination Arrangements

Ausgrid's Supply Policy - Electrical Standards (ES range of documentation).

Electrical Safety Rules

Network Management Plan

Network Standards:

- NS104 Network Project Design Plans
- NS122 Specification for Pole Mounted Distribution Substation Construction
- NS145 Pole Inspection and Treatment Procedures
- NS146 Safe Inspection Procedure for Working on Poles
- NS156 Working Near or Around Underground Cables
- NS167 Positioning of Poles and Lighting Columns
- NS179 Vegetation Safety Clearances

Service and Installation Rules

2.2 Other Standards and Documents

- AS 1289 Soil Testing - Compaction on Density
- AS 1605 Methods for sampling & analysing Timber Preservative – treated timber
- AS 2209 Timber Poles for Overhead Lines
- AS 4065 Concrete Utility Services Poles
- AS 4676 Structural design requirements for Utility Service Poles
- AS 4677 Steel Utility Service Poles
- AS 9000 Quality Management System
- AS 60300 Dependability Management
- ENA DOC 015–2006 National Guidelines for Prevention of Unauthorised Access to Electricity Infrastructure
- Relevant Industry (including ENA NENS & ISSC documentation), WorkCover Guides and Codes of Practice
- New South Wales Service and Installation Rules
- NENS 09 Guide for the Selection, Use & Maintenance of Personal Protective Equipment for Electrical Hazards
- ISSC 3 Guide to Tree Planting and Maintaining Safety Clearances near Power Lines

ISSC 7 Guide to the Prevention of Unauthorised Access to Electricity Works

2.3 Acts and Regulations

Electricity Consumer Safety Act 2004

Electricity Supply Act 1995

Electricity Supply (Consumer Safety) Regulation 2006

Electricity Supply (Safety and Network Management) Regulation 2008

Occupational Health and Safety Act 2000

Occupational Health and Safety Regulation 2001

Protection of Environment Operations Act 1997

Protection of Environment Operations Regulations

All pertinent Environmental Regulations and Acts.

3 DEFINITIONS

For the purpose of this Standard, the definitions provided below apply.

Wood Poles	Wood poles suitable for electricity transmission and distribution purposes which are hardwood poles of either full length CCA Pressure Impregnated timber poles or <i>Desapped Durable Species timber poles</i> as detailed by Australian Standards. For more details on wood poles refer to NS145 – Appendix “A”.
CCA Treated Poles	A wood pole with full length CCA (Copper Chrome Arsenate) Pressure Impregnation treatment applied to the pole to raise the durability. The treatment fully penetrates the sapwood making it highly durable and therefore allowing it to be included in the pole’s strength calculation.
Desapped Durable Species Timber Poles	Wood poles that have all their sapwood removed and are Durability Class 1 species only. Their durability comes from the chemical qualities of their heartwood, any remaining sapwood is not naturally protected.
Concrete Poles	A concrete pole manufactured to an Australian Standard for use on overhead electrical transmission lines.
Steel Poles	A steel pole manufactured ASCE Manual No.72 “Design of Steel Transmission Pole Structures” and relevant Australian Standards.
Earthing System	Shall mean and include all conductors, piping, electrodes, clamps and other connections whereby an electrical transmission line or pole transformer is earthed within the easement specified.
Raking	Is defined by an angle at which the pole is installed to offset the resultant force which tends to pull the pole to the vertical.
Customer	The customer is defined as the individual or entity presenting to Ausgrid for business dealings related to the connection and supply of electricity.
Accredited Service Provider	The individual or entity which is accredited in accordance the relevant NSW Electricity Supply Regulation and enters a contractual arrangement with an Assured Quality Contractor or Ausgrid to complete works associated with the development of the electricity distribution system.
Client	<i>An Accredited Service Provider.</i>

4 RESPONSIBILITIES

During the course of supply negotiations the *Accredited Service Provider* shall provide all information to allow Ausgrid to determine the most appropriate method of supply. Ausgrid will prepare and provide design information sufficient to enable design and construction drawings to be completed.

The *customer/applicant* for connection services is responsible for the design, supply of some materials and construction of the contestable connection work (including substations) to supply the new industrial/commercial development generally as detailed in Ausgrid's Electrical Standard ES10 Requirements for Electricity Supply to Developments. The *customer/applicant* for connection services can use either Ausgrid staff or *Accredited Service Providers* to complete the electrical design and construction for which he/she is responsible, as specified in the Design Information provided by Ausgrid for each particular project. Reference should be made to Ausgrid's Electrical Standard ES9 Agreement for Supply to Developments. The *customer/applicant* for connection services or the accredited designer is also responsible for providing local authorities and the RTA (as appropriate) with copies of the proposed construction plans at least 40 days before work is to commence, and must comply with any special requirements of these authorities. Refer also to NS104 *Network Project Design Plans*.

The *customer* (end user) is responsible for supplying and installing the portion of service mains from the street alignment to the *customer's* terminals in accordance with the NSW Service and Installation Rules and Ausgrid's Local Service and Installation Rules.

5 HANDLING PRECAUTIONS

5.1 Asbestos

All materials and equipment used for construction of Ausgrid's assets are to be free from Asbestos and or Asbestos related products. Suppliers are expected to comply with the Occupational Health and Safety Act 2000 (NSW) together with the Occupational Health and Safety Regulation 2001 (NSW) and confirm in writing that all products supplied to Ausgrid contain no Asbestos related materials.

5.2 Handling, Storing or Transporting Poles

All poles must be unloaded at the site under controlled conditions using a pole loader or a crane. In extreme circumstances where a pole loader or a crane can not be used a risk analysis approach utilising Ausgrid's safety management risk assessment process should be followed, ensuring the safety of all workers and that there is no damage to the pole.

All personnel handling, storing or transporting poles, including *Accredited Service Provider's* will be required to be familiar with the details of preferred lifting and handling techniques, including any special equipment required, recommended storing methods, the minimum number of bearing points for each particular type of pole (for transporting and storage) and the minimum dimension recommended for each bearer, together with the maximum unsupported overhang permitted during transportation.

Note: Do not use "scissor grips" when handling poles.

5.3 Wood Poles

If a CCA treated pole is damaged in a way that involves significant loss of the chemical barrier, appropriate action as detailed in this specification (see Clause 10.1) must be undertaken. The supervisor must also be advised as to the extent of the damage.

Standard leather gloves must be worn when handling *CCA treated poles*. When drilling holes for a kingbolt, or mounting a street-lighting bracket, additional eye and airway protection is required in the form of safety glasses and disposable half-face particulate filter respirators.

For the handling of burnt and burning CCA treated timber poles refer to NS145 *Pole Inspection and Treatment Procedures - "Appendix H"*.

5.4 Concrete Poles

Appropriate lifting slings should be used when handling a concrete pole such as Pole Strop slings or synthetic slings so as not to damage the concrete surface and reduce the concrete coverage of the reinforcing steel.

Information on inspection and treatment of concrete poles refer to Clause 10.2.

5.5 Steel Poles

Appropriate lifting slings should be used when handling a steel pole such as Pole Strop slings or synthetic slings so as not to damage the outer surface and reduce the protective coating.

Information on inspection and treatment of steel poles refer to Clause 10.3.

6 MARKING OF POLES

6.1 Wood Poles

Wood poles are identified in two ways:

- With an aluminium disc fixed 4 metres from the butt which gives the length, design load (kN rating), timber species, treatment type, treatment date.
- With the length, design load and timber-type painted on the butt by the supplier. The colour of the paint denotes the supplier.

For *wood poles* greater than 20 metres in length, the location of the aluminium disc will be specified.

6.2 Concrete Poles

The permanent marking may be impressed on a metal plate affixed to the pole. The plate, plaque or indentations will appear on the pole at a point 4 metres from the butt of the pole. An indented ground line reference mark is to be provided 3 metres from the bottom of the pole.

For *concrete poles* greater than 20 metres in length, the location of the metal plate will be specified.

The required information to be provided on the plate will include, name of the manufacturer, location of plant, ultimate/working strength, year of manufacture, serial number, month of manufacture, and length of pole.

6.3 Steel Poles

All *steel poles* will have a metal plate affixed to each pole section which will include the mass measurement for that section. The most critical pole marker will appear at a height between 0.8m and 2m above ground level, which should indicate other separable sections as well as details of its own section. Because the ground level can vary from pole to pole, Ausgrid will nominate a distance from the pole tip for the nameplate to be installed. The required information to be provided on the plate will include, name of the manufacturer, year of manufacture, length (m)/mass (kg) of pole, load capacity (kN), impact classification and identification reference number.

All nameplates should remain visible and legible for the intended life of the pole and should have reasonable resistance to vandalism and removal.

Poles to be direct buried are to be provided with a depth indication mark welded into the pole which also indicates the orientation the pole is to be installed.

7 DISPOSAL OF POLES

Disposal of poles should comply with Protection of Environment Operations Acts and Regulations, and Occupational Health and Safety Regulations relevant to the activities involved. In particular the disposal of *wood poles* should be carried out in accordance with 'The National Code of Practice and Guidance Note for the Safe Handling of Timber Preservatives and Treated Wood' (WorkSafe July 1989) plus any Ausgrid requirements. The guidance note gives information on the characteristics and uses of chemicals, their health hazards and relevant first aid and medical monitoring requirements.

Where disposal of poles is through transfer of ownership by sale or donation, a disclaimer should be used ensuring that in no employees claim, infer or recommend in any way that the material supplied is suitable for any particular end use.

8 EARTHING

The type of earth plate or rod will be specified on the reference drawings.

IMPORTANT: All *concrete poles* must be earthed.

9 SINKING OF HOLES

When working near underground assets comply with WorkCover's Guideline to Work near Underground Assets and all Ausgrid requirements (eg NS156 *Working Near or Around Underground Cables*).

Maximum use should be made of the mechanical plant available for sinking holes for poles. However, hand excavation must be used where utility services or obstructions exist, at least until it is clear that mechanical boring equipment can be safely employed.

In paved or concreted surfaces or where poles have been concreted in, a rectangular area of 200mm from the pole which extends down to a depth of no less than 350mm below ground level is to be maintained free from concrete or pavers to facilitate inspections.

9.1 Rock Excavation

Explosives are not used in the Sydney Basin to excavate for pole foundation.

Where rock is encountered and excavation is difficult and the bore is inadequate to cut the required hole, a vertical borer or a specialist contractor may be used. Outside the Sydney Basin where there is no other option a specialist contractor may consider using explosives to excavate difficult rock.

9.2 Utility Services and Obstructions

Be aware of the possibility of underground pipes, cables etc, belonging not only to Ausgrid but also to other utilities. Before digging into unknown ground it is essential to check on the location of any underground services in the vicinity.

To determine if underground service assets exist in a particular location, contact the Dial Before You Dig Service, telephone 1100 (business hours), or internet www.dialbeforeyoudig.com.au. This is a free service, providing information on which utility has an interest in a particular location and the relevant contact details.

In all locations in Ausgrid's network franchise area the requirements of NS156, (especially Clause 2.1, to determine the presence of cables before commencing work), apply for routine/urgent/emergency pole hole sinking. When plans are not sourced via a DialBeforeYouDig enquiry, they are to be obtained directly from the asset owner, or other precautions taken to determine the presence of underground assets.

Where doubt exists as to the presence and location of obstructions, pipes, or cables, sinking should be carried out by hand to a depth of at least 900 mm, or until rock or shale is encountered.

Before boring, check all the necessary utilities' underground construction plans, to identify where the underground construction is located, before hole sinking begins.

9.3 Pole Sinking Depths

Please refer to NS220, *Overhead Design Manual* and AS7000, *Overhead Line Design – Detailed Procedures*.

10 POLE ERECTION

10.1 Wood Pole Inspection and Treatment

Should there be damage of the sapwood which is impregnated with a chemical barrier or large pole butts that require trimming such as to expose untreated timber in the "below ground - line " section, then special treatment of the exposed area will be required. Exposed areas on *CCA treated poles* will be treated by hand painting with a preservative surface - treatment compound (copper naphthenate oil - CN timber oil).

For non *CCA treated poles*, bioguard wrap is to be installed externally around the pole 50 mm below the groundline at the same time the pole is erected.

10.2 Concrete Pole Inspections and Treatment

All *concrete poles* will be inspected and found to be free from any defects such as transport damage or surface cracks, honeycombing. Depressions or bulges must not exceed 2 mm in height or depth provided that the maximum cover is maintained and the depressions or bulges do not exceed in any direction for more than 100 mm.

Drilling, cutting or grinding of a concrete pole will not be permitted unless specifically approved by a designated Ausgrid representative who is in attendance during the procedure.

10.3 Steel Pole Inspections and Treatment

All *steel poles* will be inspected and found to be free from any defects such as general transport damage, dents, surface cracks or coating defects.

Should there be damage to the galvanised coating of the pole the exposed area will be treated by hand painting with GALMET or equivalent.

Steel poles can have epoxy mastic paint coverage or an insulated cover in the groundline region and great care should be taken not to damage the coating/cover.

Drilling, cutting or grinding of a steel pole will not be permitted unless specifically approved by a designated Ausgrid representative who is in attendance during the procedure.

10.4 Erecting Poles or Columns in Proximity to Mains

(a) Minimum Safe Distances for Working near Overhead Power Lines

The minimum safe working distances are distances which must be maintained by people, and their tools and equipment, when they are near live exposed conductors. Work on or near Ausgrid's mains and apparatus may only be carried out in accordance with the Ausgrid's Electrical Safety Rules.

(b) Erecting Poles Through Bare Live LV Mains

For work on the ground or in an earthed situation, where there is a reasonable risk of the pole contacting exposed live low voltage conductors, precautions such as applying temporary insulation to the pole or the low voltage conductors and using insulated pole handling tools or wearing insulating gloves should be taken by personnel handling or touching the pole.

Footwear must be worn and be appropriate for the conditions at the site.

Precautions are also recommended for new *wood poles* or impregnated (e.g. CCA treated) poles.

(c) Erecting Poles in Proximity to HV Mains

Minimum Safe working distances must always be maintained.

10.5 Raking and Staying of Poles with Unbalanced Loads

A pole which is to be subjected to a resultant horizontal force (e.g. angle or termination pole) should be raked (not more than 2 heads) so that the resultant force tends to pull the pole to the vertical. The vertical position is to be established by sighting with a plumb bob and the pole is then erected at an angle to the vertical.

A pole which is to be subjected to unbalanced loads which would exceed the permissible design load limits of the pole, must be stayed in accordance with Ausgrid drawing B-61501, prior to attaching the unbalanced loads to the pole. If a concrete pole is used, this must be reported to Ausgrid in advance, so that any additional precautions to protect the concrete from crushing by the stay wire can be determined.

10.6 Back Filling

To ensure the stability of erected poles, approved type back filling is to be used.

The compaction level for the layered backfill is to be 98% of Standard Compaction, with 1-2% optimum moisture content. Refer to AS 1289 Soil Testing - Compaction and Density.

Should backfilling be carried out using hole spoil a final bearing capacity in excess of 300 kPa/m² is required around the backfilled area.

Alternatively, the hole is to be layer back filled with DGB-10 Roadbase or other approved type of back filling.

Back filling should be ram compacted every 150 mm thick to ground line and shall fill the hole. The 350 mm below ground level to the actual ground level should be filled with loamy type soil to facilitate future inspections.

Poles for pole mounted distribution substations must be back-filled as specified in NS122 *Specification for Pole Mounted Distribution Substation Construction*.

10.7 Footing Strength

Poles sunk to Ausgrid's standard sinking depth will have adequate footing strength in medium bearing strength soils (300kPa/m²).

Where poor bearing strength soils are encountered, an increase in sinking depth will significantly increase footing strength, and is the preferred method of increasing footing strength where required. For example a 25% increase in sinking depth will almost double the footing strength.

Where increased sinking cannot be accomplished, baulking is effective, but requires plenty of room - free from services, obstructions, kerbs, etc see Clause 10.8 Baulking.

Concreting of the butt has little effect on footing strength, compared to increasing sinking depth. For example, to double the footing strength of a pole using concrete backfill requires the effective diameter of the in-ground section of the pole to be doubled - meaning that a pole with an in-ground diameter of 220 mm must have 110 mm of concrete placed evenly around the pole down to butt level so the diameter below ground now becomes 440 mm.

Poles must be backfilled in accordance with Clause 10.6 to ensure pole stability. Concrete must not be used as a substitute for poor pole stabilisation practises. Concreting should only be used where quick stabilisation of the soil is required such as for Pole Transformer poles.

10.8 Baulking

The figure below shows baulking using a log heel and a stone toe.

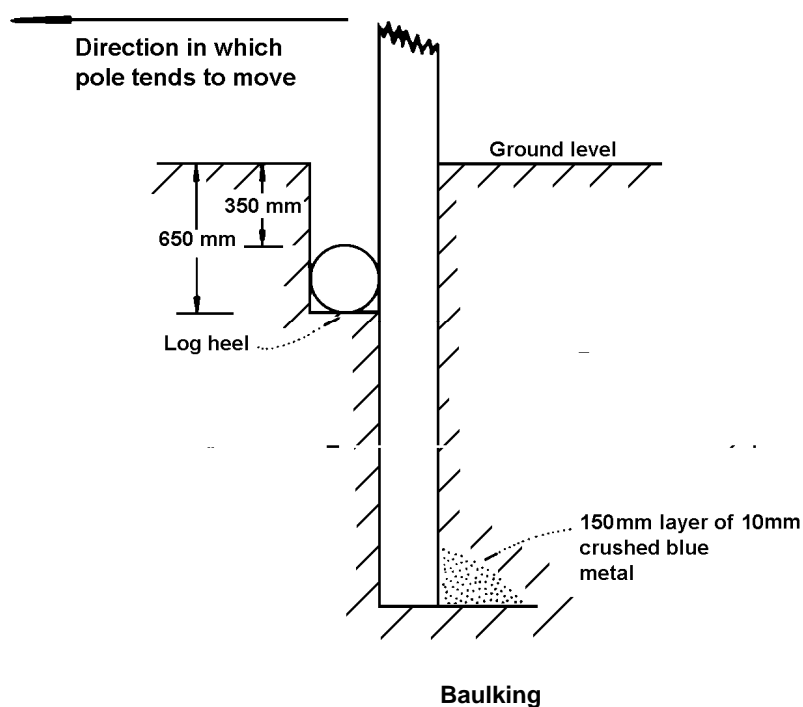

10.9 Concreting Butt

Concreting should extend from the butt to a point 350 mm below final ground line. Poles must never be concreted to ground level.

Except in special circumstances poles will not be concreted in rock. Where an obstruction (eg water pipe) is also close to the butt of a pole, the obstruction should be shielded from concrete encasement by a suitable barrier.

Poles for pole mounted distribution substations must be concreted as specified in NS122.

10.10 Vegetation Clearing for New Poles and Lines

Accredited Service Providers designing new overhead lines and poles must comply with the requirements of the Industry Safety Steering Committee document ISSC 3 – Guide to Tree Planting and Maintaining Safety Clearances Near Power Lines.

Prior to erecting any new or replacement pole, vegetation clearances must be in accordance with the requirements of NS179 *Vegetation Safety Clearances*. The clearances specified in NS179 are to prevail over the clearances indicated in document ISSC 3.

Vegetation clearance work must be carried out in accordance with Ausgrid's Electrical Safety Rules.

10.11 Restoration of Surfaces after Installation of Poles

Ground surfaces which have been disturbed during excavation of pole holes and during installation of poles must be restored in accordance with this clause. This clause applies to the final backfill top-up and surface restoration after the pole hole has been backfilled in accordance with Clause 10.6 of this Network Standard, and Clauses 10.7, 10.8 and 10.9, where applicable.

Methods adopted for backfilling and restoring excavated areas around poles must achieve a clean and tidy result. This will reduce the number of *customer* complaints. Any complaint about the condition of a site must be attended within 24 hours of notification. If work has been performed by an *Accredited Service Provider* the costs incurred in rectifying any complaint are to be borne by the *Accredited Service Provider*.

10.11.1 Unpaved Areas

In unpaved areas, the depression around the pole is to be restored firstly with approved backfill material complying with Clause 10.6. Stones and vegetation must be removed from the backfill material. The backfill material is to be firmly tamped down with a suitable tool so that it finishes slightly below the general ground level. The top surface is then to be filled with clean stone-free sandy loam. The sandy loam is to be tamped down and sloped away from the pole so that the finished level at the pole is 20 mm above the surrounding general ground level. The work area is to be cleaned with a broom and all surplus material is to be removed from the site.

10.11.2 Paved Areas

Any concrete or decorative paving must terminate a minimum of 200 mm from the face of a timber pole, to facilitate pole inspection and maintenance.

In paved areas, the depression around the pole is to be restored firstly with approved backfill material complying with Clause 10.6. Stones and vegetation must be removed from the backfill material. The backfill material is to be firmly tamped with a suitable tool so that it finishes approximately 50 mm below the level of the pavement. All excess backfill material is to be cleaned from the surface of the pole and from the edges of the surrounding paving.

Where the pavement is paving tiles, the tiles are to be cut as required and placed to fit neatly around the pole. The tiles are to be laid on a sand bed and the finished surface is to join level with the surrounding undisturbed paving tiles and be slightly higher at the pole. Any small gaps between the paving tiles are to be filled with sand.

Where the paved surface is other than paving tiles, the top surface of the inspection area around the pole is to be reinstated with cold bituminous pre-mix material. The bituminous pre-mix material is to be tamped down and sloped away from the pole so that the finished level at the pole is 20 mm above the surrounding pavement level. The bituminous pre-mix material is to be finished slightly above the level of the surrounding paving to allow for settling, but not to the extent that a trip hazard would be created. The work area is to be cleaned with a broom and all surplus material is to be removed from the site.

The reinstatement of paved areas is to be completed as detailed above within 24 hours of the installation being carried out.

Permanent restoration of the affected paved areas will also be in accordance with the requirements of the local road authority.

Part of the work performed by an *Accredited Service Provider* includes the permanent reinstatement and restoration of the paved areas.

11 REMOVAL OF POLES

11.1 General

When a pole is to be removed, it should be "pushed" from the ground by two hydraulic extraction jacks, while a mobile crane or borer erector vehicle is attached at or just above the point of balance. Two jacks, installed diametrically opposite, are used to ensure that the pole emerges vertically out of the ground and can be easily lifted directly onto a pole jinker. The mobile crane or borer erector vehicle must not attempt to assist the hydraulic jacks in the removal of the pole. The mobile crane or borer erector vehicle function is to steady the pole and receive it after extraction from the ground.

Note: Mobile cranes are not permitted to pull against unknown extraction forces.

Before extracting a pole whose butt has been concreted, a check should be made for possible underground utility construction close to the pole. Damage to pipes or cables will result if they are encased in concrete and pulled up with the pole butt.

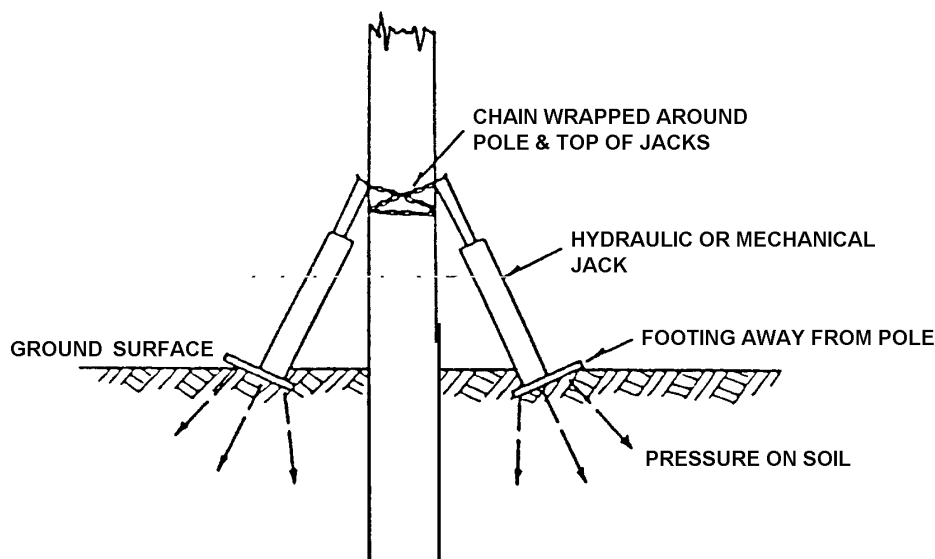

Correct Use of Hydraulic Jacks

11.2 Removal of Pole Butts

All pole butts are to be removed where practicable. When removal of the butt is not practicable (eg. a pole concreted in rock) the butt is to be cut off not less than 250 mm below ground level. If the butt is infested with termites, Ausgrid Contract Operations (telephone: (02) 9410 5466) is to be notified so a suitable treatment can be carried out.

11.3 Removal of Pole Attachments

The normal risk management process must be undertaken. Work on free-standing poles should be kept to a minimum. In some circumstances all attachments will be removed while working from an EWP and possibly the head of the pole sawn-off below the existing conductors; and in other circumstances as many attachments as possible would be left on the pole with the removal of the remaining attachments done after the pole has been removed. There are many variables that could affect the safety of the work and each circumstance needs to be carefully assessed before a decision is made on the procedure for the removal of the pole's attachments. When a borer erector is used for the removal of a pole (see Clause 11.1) consideration should be given to the removal of all attachments so as not to foul the jaws of the borer erector.

Note: The pole identification number MUST remain with the pole, and any new pole has a new identification label installed.

The strength of the pole and the loads which are applied to that pole is critical and must be assessed. Before a pole, is made free-standing it must be inspected in accordance with NS146 *Safe Inspection Procedure for Working on Poles*. If an authorised person is dissatisfied with the pole condition, or the pole is shown by the inspection to be unsound, or if the pole is suspect, or condemned, the pole must not be climbed and stripped unless it is stayed or supported in accordance with Section 12.

11.4 Disposal of Wood Poles with Steel Reinforcing 'Nails' Attached

This clause provides information on pole reinforcement with steel 'nails' and outlines the procedures which must be followed when poles with steel reinforcing nails attached are recovered from service.

11.4.1 Pole Reinforcement

Ausgrid currently reinforces all *wood poles* where timber degradation at or below groundline has reduced the residual strength of the pole to 50% or less, and the condition of the above ground section of the pole is suitable for a minimum of 10 years' service. Poles suitable for reinforcement are nominated by Network Contracts for the Pole Reinforcement Contractor to attach steel reinforcing nails.

Occasionally, the presence of below ground obstructions, such as baulks, concrete or rock, may prevent pole reinforcement nailing from being completed after the task has commenced. The Pole Reinforcement Contractor has been instructed to not remove any reinforcing nails that cannot be driven to the required depth, because removal could destabilise the pole. When the nailing is unsuccessful, the Pole Reinforcement Contractor must notify the relevant Network Contracts Officer who will arrange to have the nail removed and the pole replaced. The Pole Reinforcement Contractor can be present at the removal to collect the nail, or the nail can be stored for collection later by the Contractor. In these cases, Ausgrid is not charged, however the nail remains the property of the Pole Reinforcement Contractor and Ausgrid is obliged to provide for its collection.

11.4.2 Reinforced Poles Removed From Service

When the above ground condition of a reinforced pole deteriorates to the point where replacement is required, the pole and reinforcing nail are removed from the ground as a unit, where possible. The bolts are not to be removed. Reinforcing nails are designed to last 20 years with no maintenance, and may last considerably longer when corrosion prevention maintenance has been carried out. They may be re-used a number of times depending on environmental and other conditions, and therefore must not be discarded when removed from service.

In situations where the pole cannot be jacked out of the ground, it may be necessary to cut the pole below ground and use oxy-acetylene equipment to cut the nail below ground. Where the nails are cut off, the cut piece should be discarded.

11.4.3 Notification of Reinforced Poles Removed

When a reinforced pole is removed, notification must be sent to the relevant Contracts Officer. The notification should include the date of removal, the reason for replacement, the pole number and the location of the pole. The Contracts Officer is to notify the Pole Reinforcement Contractor of the reinforced poles removed so that arrangements can be made by the Pole Reinforcement Contractor to detach and collect the nails.

11.4.4 Storage of Poles with Reinforcing 'Nails' Attached

Poles removed from service with reinforcing nails attached, are to be stored in a designated storage area where the Pole Reinforcement Contractor can attend and safely remove the nails from the poles.

After the nails have been removed from poles, the poles can then be disposed of in the usual manner.

11.5 Restoration of Surfaces after Removal of Poles

Pole holes and ground surfaces which have been disturbed during removal of poles, or where poles have been cut off, must be restored in accordance with this clause.

To prevent danger to the public, barricades must be placed at sites where poles have been removed or cut off, until the surfaces are restored in accordance with this clause.

Methods adopted for backfilling pole holes and restoring excavated areas around pole holes must achieve a clean and tidy result. This will reduce the number of *customer* complaints. Any complaint about the condition of a site must be attended to within 24 hours of notification. If the work has been done by an *Accredited Service Provider* the costs incurred in rectifying any complaint are to be borne by the *Accredited Service Provider*.

Backfill material must comply with Clause 10.6.

11.5.1 Unpaved Areas

In unpaved areas, the pole hole is to be restored firstly with approved backfill material. The backfill material is to be firmly tamped down with a suitable tool so that it finishes slightly below the general ground level. The top surface is then to be filled with clean stone-free sandy loam. The sandy loam is to be tamped down and finished level with the surrounding general ground level. The work area is to be cleaned with a broom and all surplus material is to be removed from the site.

The reinstatement of unpaved areas is to be completed as detailed above within 24 hours of pole removal.

11.5.2 Paved Areas

In paved areas, the pole hole is to be restored firstly with approved backfill material. The backfill material is to be firmly tamped with a suitable tool so that it finishes approximately 50 mm below the level of the pavement. All excess backfill material is to be cleaned from the surrounding paving.

The top surface is to be reinstated with cold bituminous pre-mix material. The bituminous pre-mix material is to be tamped down and finished slightly above the surrounding pavement level to allow for settling, but not to the extent that a trip hazard would be created. The work area is to be cleaned with a broom and all surplus material is to be removed from the site.

The reinstatement of paved areas is to be completed as detailed above within 24 hours of pole removal.

Permanent restoration of the affected paved areas will also be in accordance with the requirements of the local road authority.

Part of the work performed by an *Accredited Service Provider* includes the permanent reinstatement and restoration of the paved areas.

12 METHOD OF SECURING CONDEMNED POLES

Condemned, conditionally serviceable or suspect poles must not be climbed or worked on unless secured in an approved manner (Methods 1 & 2 or a combination).

Condemned poles should be replaced as soon as practicable. Some factors which can restrict the removal of a condemned pole, is the existence of telecommunications infrastructure, availability of lineworkers and safety concerns (e.g. vehicle/pedestrian traffic, school zones etc).

Poles must be secured using one of the following methods suitable to the prevailing conditions:

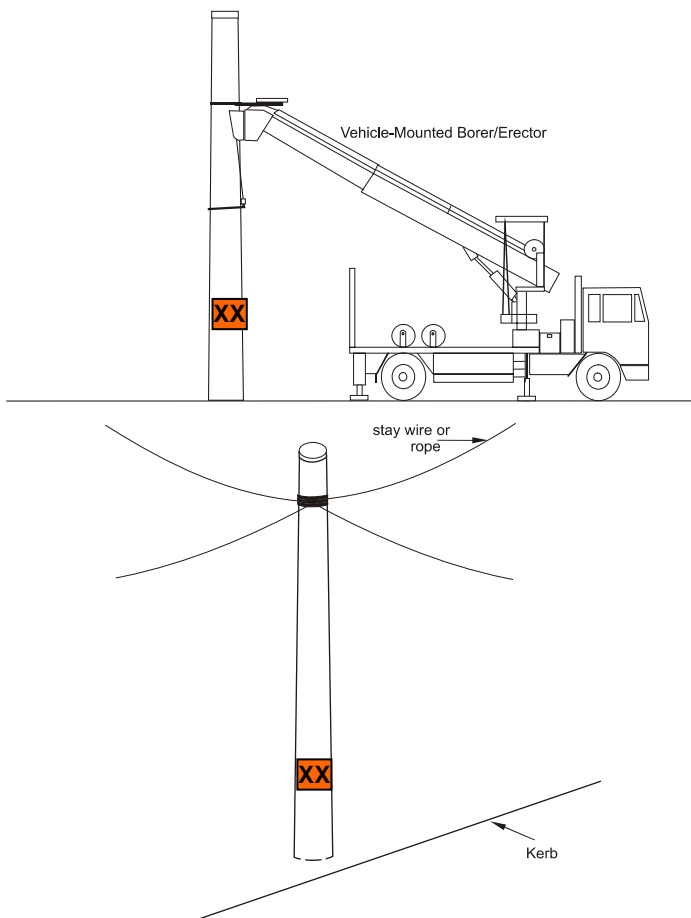

Method 1

Hold the pole above the point of balance using a mobile crane or pole erecting vehicle.

Method 2

Erect a minimum of 3 stays to the top of the pole above the point of balance. The stays should consist of stay wire or rope and be solidly fixed to the pole and adjacent solid objects such as large trees or heavy vehicles. The stays must be placed at an angle of approximately 120 degrees apart for 3 stays or 90 degrees apart for 4 stays, and in such a manner that the pole cannot move under load.

In difficult locations where the normal risk assessment process allows a combination of stays and pole pikes may be used to secure the pole.

Note: A condemned, conditionally serviceable or suspect pole must be stabilised by one of the above methods before being climbed or worked upon. A combination of the above methods may be necessary in some circumstances.

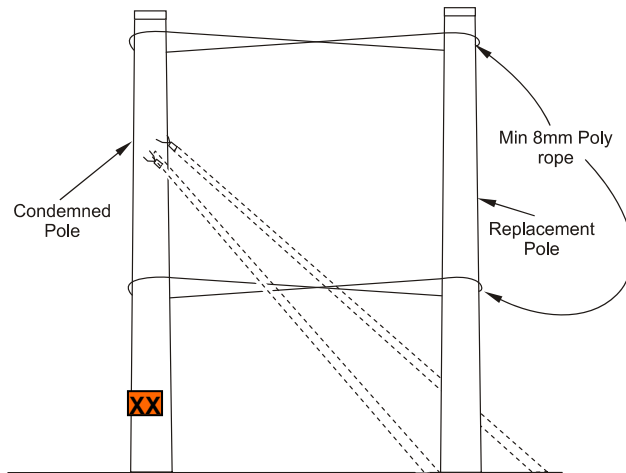
**Method 3** (Not for climbing or working on)

Working from an Elevated Working Platform (EWP) or from the new replacement pole, lash the condemned pole with polypropylene rope to prevent the condemned pole falling. (Refer to Appendix G & H for details.)

Method 1 or temporary stay(s) may be used for securing the pole to make safe before lashing.

In certain situations pole pikes may be utilised to make the pole safe but not secure to work on (Refer to Appendix H for using pikes).

Note: At difficult locations the normal risk assessment risk management process must be undertaken and a combination of stays, pole lashings and pikes will need to be used for “making safe” condemned poles.

13 STORES AND MATERIALS

Contractors must only use approved products on the network. Ausgrid should be contacted regarding approved products. Alternative products may be submitted to Ausgrid for approval. A fee for the approval of alternative products for use on the network will be negotiated.

To purchase materials from Ausgrid, the Project Manager must contact the "Project Officer Network Procurement" on telephone number (02) 9394 6034. All materials will be made available for the *Client* to pick up from:

**Central Warehouse
2 Mayvic Street
Chullora NSW 2190**

Alternatively, the *Accredited Service Provider* may obtain material from other sources provided the quality assurance and environmental management system requirements are met. Materials must comply with Ausgrid's relevant specifications.

Wood poles must be as specified in Ausgrid's Specification for Overhead Line Supports (Poles). The specification and acceptance procedures for *wood poles* are included as Appendix E.

Particular attention is drawn to the requirement for pre-acceptance inspection by Ausgrid's Timber Inspector at the point of supply. If the wood pole supplier does not ensure that this requirement is complied with, the reasonable cost of any subsequent pole inspection that Ausgrid may deem necessary shall be charged to the *Accredited Service Provider*. Any poles erected which do not comply with Ausgrid's requirements will be defected and must be replaced at the *Accredited Service Provider's* cost prior to being connected into Ausgrid's network.

Approved timber species poles selected for the following structures must be of durability class1 hardwood timber, as specified in AS 2209 Timber Poles for Overhead Lines, Appendix B:

- Pole mounted distribution substations.
- Underground to overhead connection poles.

APPENDIX A MATERIAL STOCK CODE NUMBERS

Item	Stockcode Number
Poles, line construction wood, preservative treated (Height/ tipload):	
8 m/4 kN	146654
9.5 m/4 kN	146662
9.5 m/8 kN	146670
11 m/6 kN	146688
11 m/8 kN	146696
11 m/12 kN	146704
12.5 m/6 kN	146712
12.5 m/8 kN	146720
12.5 m/12 kN	146738
14 m/8 kN	146746
14 m/12 kN	146753
Surface coating repairs:	
Copper naphthenate base paint 2 litres	146332
Disposable bag, plastic (Length 1200 mm, Width 700 mm, Thickness 200 microns)	147645

APPENDIX B FOOTWAY ALLOCATIONS

New Footway Areas From 1.1.91 - Sydney Region

STREETS OPENING CONFERENCE
PUBLIC UTILITY MAINS
 Allocation of space on 3.5m, 4m, 5m, and 6m footways
 Adopted by Conference Date 18/12/90

These allocations of space for public utility mains apply to footways in new roads or new subdivisions, dedicated after 1.1.91, where all services are underground. In all other cases, the original allocations apply.

Where a public body in providing poles, underground mains, or street lighting columns wishes to encroach on space allocated to another body, it should arrange prior consultation and agreement with the other body concerned.

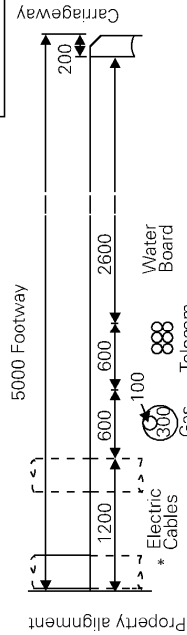
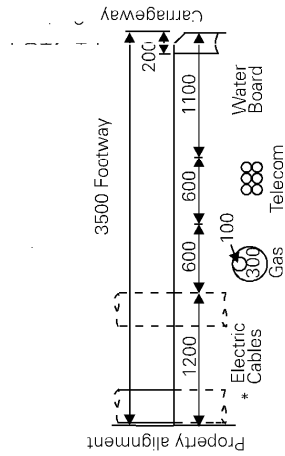
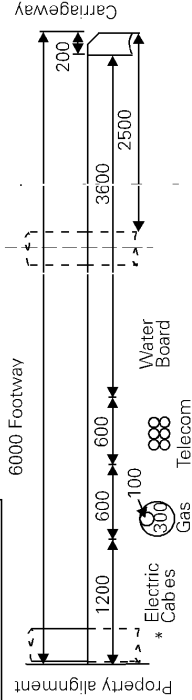
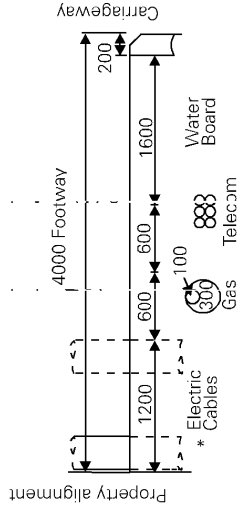

* The preferred position for street lighting columns is adjacent to the property alignment. An alternative position is shown by dashed lines.

Existing Footway Areas Before 1.1.91 - Sydney Region

For streets outside city boundary

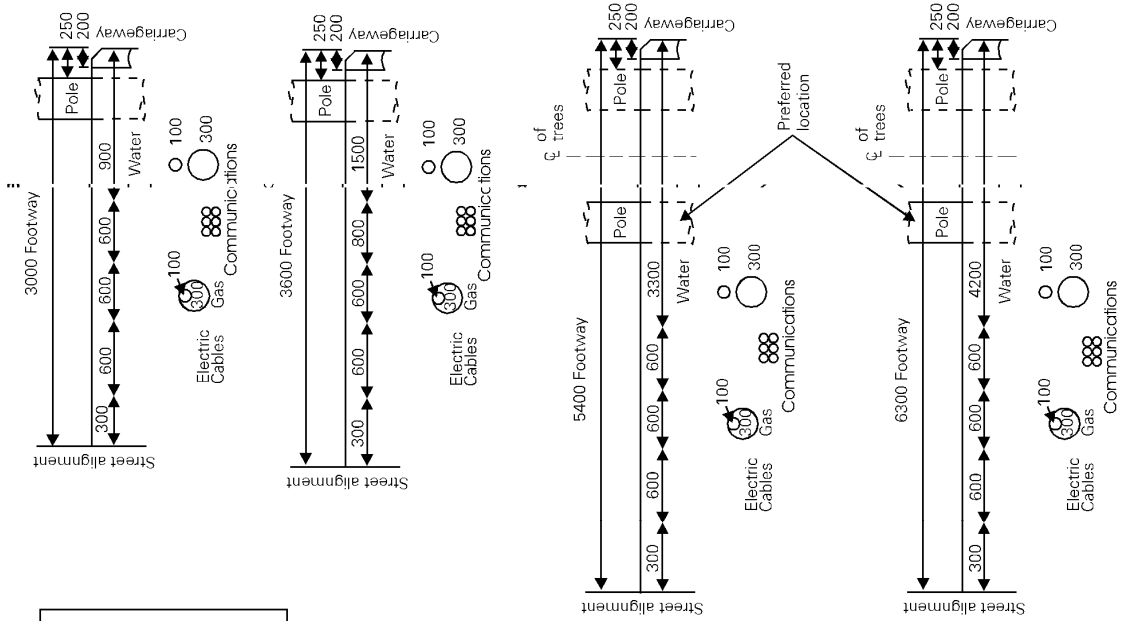

STREETS OPENING CONFERENCE

PUBLIC UTILITY MAINS

Allocation of space on 3m, 3.6m, 5.4m, and 6.3m footways

For streets within city boundary

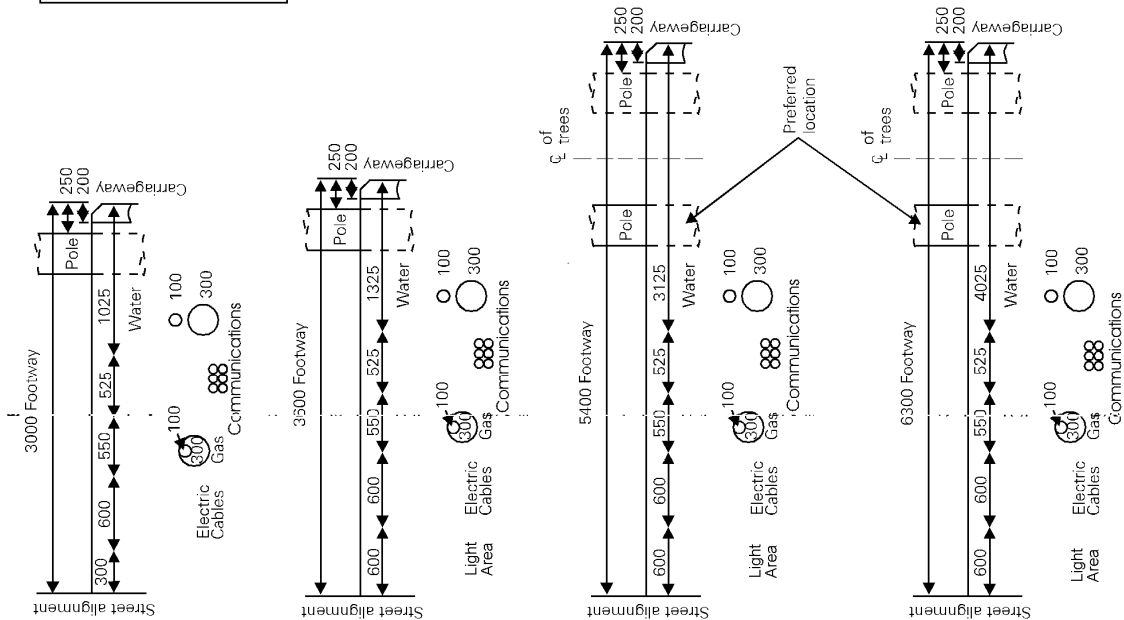

Footway Allocations - Central Coast Region

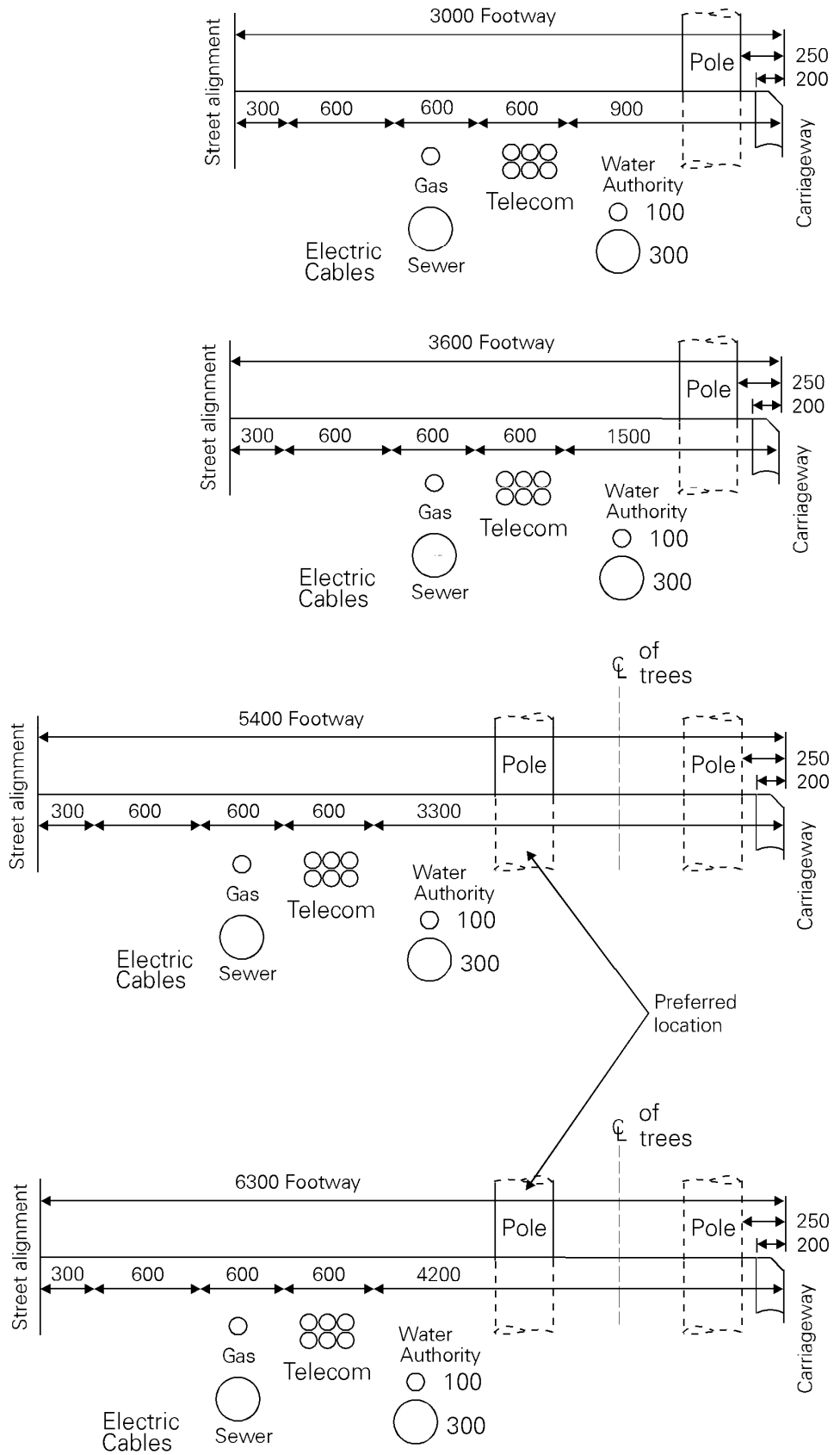

Footway Allocations- Maitland and Cessnock City Councils

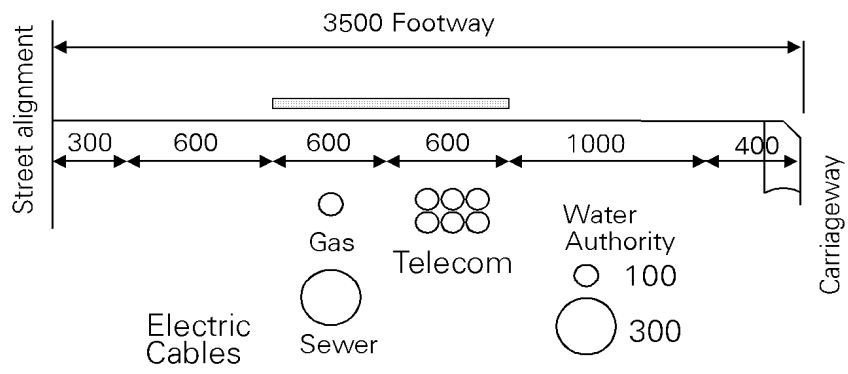

Footway Allocations - Muswellbrook, Merriwa and Scone Shire Councils

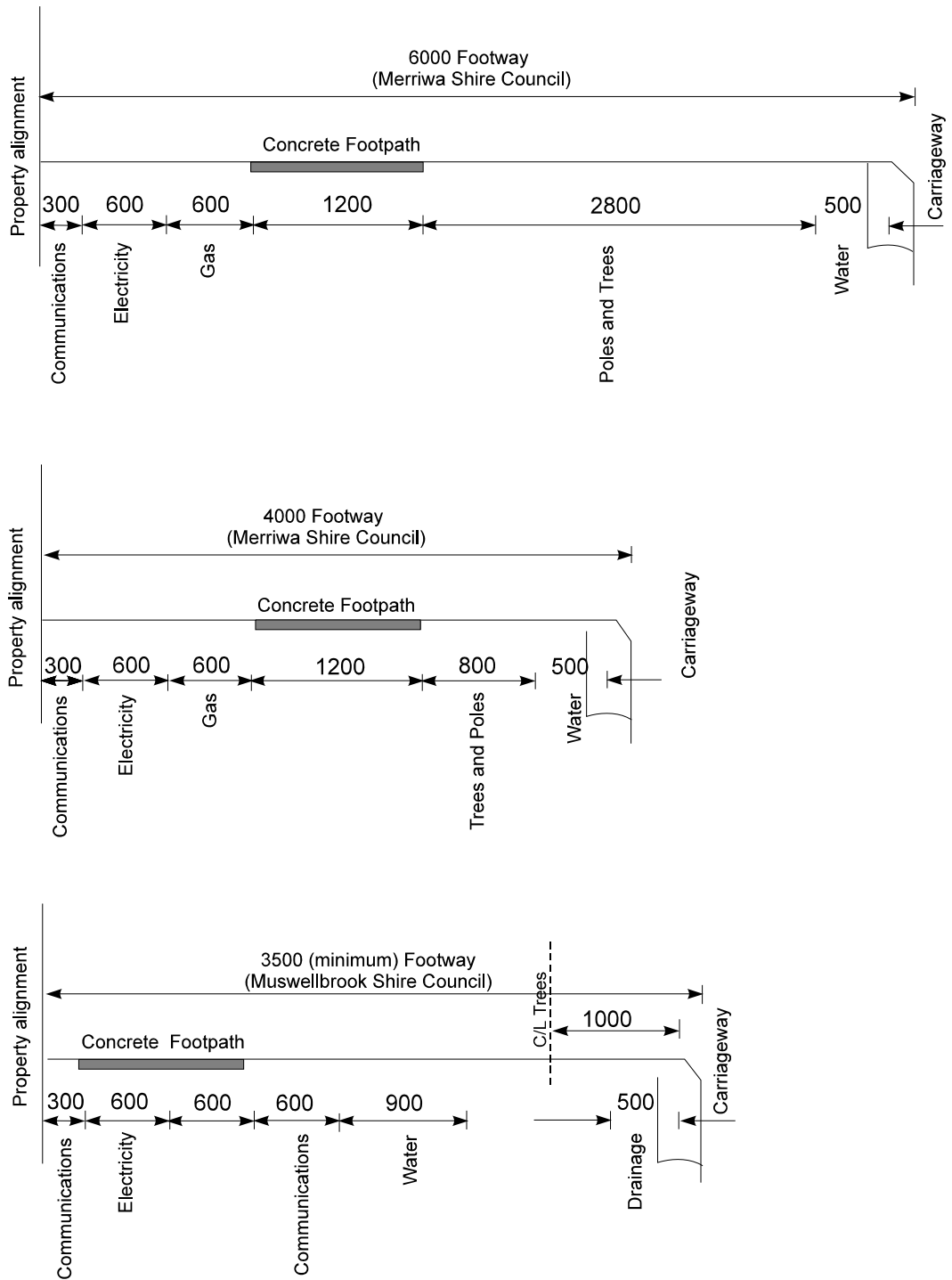

Note: For Scone Shire Council the electricity allocation is between 300 and 900 mm from the boundry location.

All dimensions are in millimetres.

Footway Allocations - Lake Macquarie and Newcastle City Councils and Port Stephens Shire Council

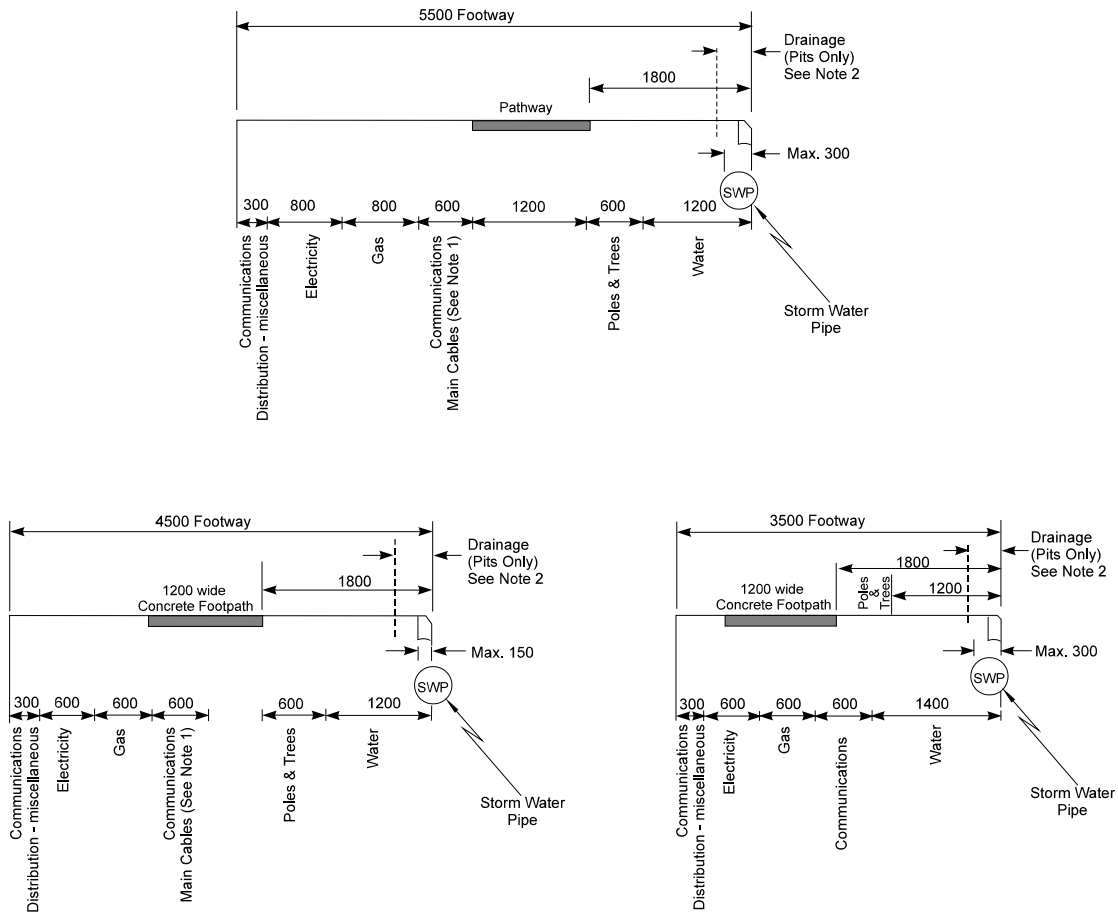

Note 1: Pathway allocation available to accommodate telecommunication main cables and access holes.

Note 2: Should be in roadway and should not encroach in footpath more than 380mm.

All dimensions are in millimetres.

Footway Allocations - Singleton Shire Council

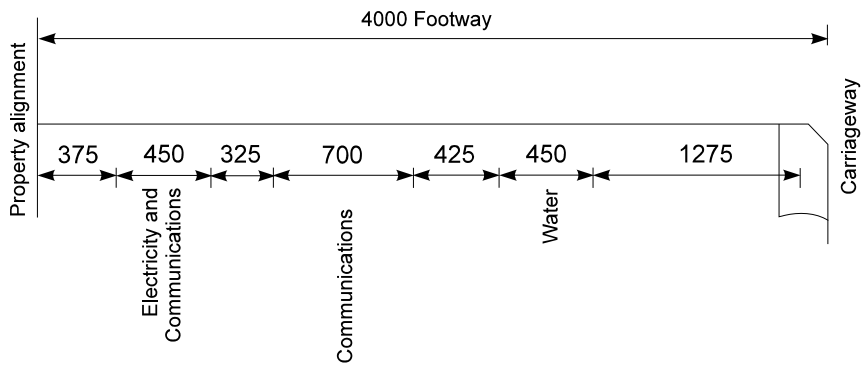

All dimensions are in millimetres.

APPENDIX C CHECKLIST FOR POLES

C1 Site		Yes	No	N/A
1	Has the site been surveyed and pegged?	<input type="checkbox"/>	<input type="checkbox"/>	<input type="checkbox"/>
2	Has the site been checked against 'Streets Opening' drawing?	<input type="checkbox"/>	<input type="checkbox"/>	<input type="checkbox"/>
3	Has the site been checked for any services within 300 mm of the position of the proposed hole?	<input type="checkbox"/>	<input type="checkbox"/>	
4	If the hole is in proximity of an underground service, has that relevant authority been contacted for an inspection?	<input type="checkbox"/>	<input type="checkbox"/>	<input type="checkbox"/>
6	Have all relevant acts, laws, standards and instructions been complied with?	<input type="checkbox"/>	<input type="checkbox"/>	
C2 Installation		Yes	No	N/A
1	Is access to the pole available?	<input type="checkbox"/>	<input type="checkbox"/>	
2	Have relevant Ausgrid permits been issued?	<input type="checkbox"/>	<input type="checkbox"/>	<input type="checkbox"/>
3	Have all required drawings and details for these works been issued for approval?	<input type="checkbox"/>	<input type="checkbox"/>	<input type="checkbox"/>
4	Has a full parts list including hardware been issued for approval?	<input type="checkbox"/>	<input type="checkbox"/>	<input type="checkbox"/>
5	Has the pole been inspected, butt stamped and disked?	<input type="checkbox"/>	<input type="checkbox"/>	
6	Has the pole been inspected prior to erection?	<input type="checkbox"/>	<input type="checkbox"/>	
7	Does the LV OH wiring require Torapoli piping?	<input type="checkbox"/>	<input type="checkbox"/>	
8	Is HV or LV isolation required?	<input type="checkbox"/>	<input type="checkbox"/>	
10	Has the correct pole rake been set?	<input type="checkbox"/>	<input type="checkbox"/>	<input type="checkbox"/>
11	Has the pole been back filled with DGB-10 road base or approved back fill from the butt to within 350 mm of ground level?	<input type="checkbox"/>	<input type="checkbox"/>	
12	Has specified staged compaction been achieved?	<input type="checkbox"/>	<input type="checkbox"/>	
13	Has the final 350 mm of hole been fitted with approved fine material (e.g. sand)?	<input type="checkbox"/>	<input type="checkbox"/>	
14	Was a pole required to be removed in conjunction with this new pole installation?	<input type="checkbox"/>	<input type="checkbox"/>	
15	Was pole removal carried out according to specification?	<input type="checkbox"/>	<input type="checkbox"/>	<input type="checkbox"/>

Accredited
Service Provider: _____ Signature: _____

Date: _____

APPENDIX D VEGETATION CLEARANCE REQUIREMENTS

Refer to and comply with NS179 *Vegetation Safety Clearances*.

APPENDIX E WOOD POLE SPECIFICATION AND ACCEPTANCE PROCEDURES

E.1 COMMON REQUIREMENTS

E.1.1 Extent of Specification

This specification, including drawing and schedules, provides for the supply, consignment stocking and delivery of preservative treated hardwood poles and untreated hardwood poles.

E.1.2 Purpose of Equipment

The poles are required for the construction of overhead electric power lines.

E.1.3 Description of Goods

The poles are required for the construction of overhead electric power lines.

Table 1 General Purpose Poles.

Item No.	Pole Designation Rating kN	Pole Length (m)	Pole Diameter (mm) Strength Group SD1				Pole Diameter (mm) Strength Group SD2			
			Top	Ground Line	Butt	Mass (Kg)	Top	Ground Line	Butt	Mass (Kg)
1	8 m/4 kN	8	163	229	241	314	173	239	251	311
2	8 m/6 kN	8	195	261	272	418	210	276	287	425
3	8 m/8 kN	8	221	287	298	515	236	302	313	518
4	8 m/12 kN	8	258	324	335	670	278	344	355	687
5	9.5 m/4 kN	9.5	164	243	256	404	179	258	271	417
6	9.5 m/6kN	9.5	195	275	287	532	210	290	302	539
7	9.5 m/8 kN	9.5	227	306	319	678	242	321	334	678
8	9.5 m/12 kN	9.5	269	348	361	899	289	368	381	915
12	11 m/6 kN	11	201	294	308	689	216	309	323	693
13	11 m/8 kN	11	227	320	334	833	242	335	349	831
14	11 m/12 kN	11	275	368	382	1134	295	388	402	1148
15	12.5 m/4 kN	12.5	160	266	281	594	175	281	296	608
16	12.5 m/6 kN	12.5	197	303	318	804	217	323	338	838
17	12.5 m/8 kN	12.5	228	335	350	1008	248	355	370	1034
19	14 m/6 kN	14	197	317	334	960	212	332	349	962
20	14 m/8 kN	14	229	349	365	1195	249	369	385	1222
22	15.5 m/6 kN	15.5	193	326	344	1092	213	346	364	1130
23	15.5 m/8 kN	15.5	229	363	380	1399	244	378	395	1383
25	15.5m/12kN	15.5	281	415	432	1904	301	435	452	1907
26	17 m/6 kN	17	188	335	354	1230	208	355	374	1270
27	17 m/8 kN	17	225	372	391	1570	245	392	411	1597
31	17 m/12 kN	17	277	424	443	2135	302	449	468	2191
32	18.5 m/6 kN	18.5	189	349	369	1423	209	369	389	1463
33	18.5 m/8 kN	18.5	220	381	401	1749	240	401	421	1776
37	18.5 m/12 kN	18.5	277	438	458	2426	302	463	483	2483
38	20 m/8 kN	20	216	390	411	1935	241	415	436	2019
39	20 m/12 kN	20	273	447	469	2680	298	472	494	2739
40	21.5 m/8 kN	21.5	211	399	421	2129	236	424	446	2217
41	21.5 m/12 kN	21.5	273	461	483	3006	298	486	508	3064
42	23 m/12 kN	23	269	470	494	3277	294	495	519	3335

Notes:

1. Ground line pole dimensions are the minimum required to meet strength rating for timber. Pole top diameter is nominal. Pole diameter at any point below

nominal ground line must not be less than the ground line dimension, and must not exceed the ground line dimension by more than 6%.

2. Nominal ground line assumed to be 1metre plus 10% of pole length.
3. Strength grade 1 timber = 100 MPa max. Permissible extreme fibre stress.
Strength grade 2 timber = 85 MPa max. Permissible extreme fibre stress.

Table 2 Special Purpose Poles.

Item No.	Pole Designation	Pole	Pole Diameter (mm) Strength Group SD1				Pole Diameter (mm) Strength Group SD2			
	Rating kN	Length (m)	Top	Ground Line	Butt	Mass (Kg)	Top	Ground Line	Butt	Mass (Kg)
9	10 m/25 kN	10	363	447	460	1614	388	472	485	1633
10	10 m/35 kN	10	415	499	512	2044	440	524	537	2042
11	10 m/45 kN	10	457	541	554	2428	487	571	584	2451
18	12.5 m/12 kN	12.5	275	382	397	1355	295	402	417	1367
21	14 m/12 kN	14	276	396	412	1594	301	421	437	1647
24	15.5 m/16 kN	15.5	318	452	469	2311	343	477	494	2348
28	17 m/16 kN	17	319	466	485	2643	344	491	510	2679
29	17 m/20 kN	17	360	507	526	3207	385	532	551	3216
30	17 m/25 kN	17	397	544	563	3749	427	574	593	3803
34	18.5 m/16 kN	18.5	319	480	500	2998	349	510	530	3099
35	18.5 m/20 kN	18.5	361	521	541	3623	386	546	566	3625
36	18.5 m/25 kN	18.5	397	558	578	4222	427	588	608	4275

E.1.4 Average Weights of Poles

The *Accredited Service Provider* must provide, or must ensure that their supplier provides, Ausgrid's Timber Inspector with a list of the normal weights of all poles, and maximum weight deviations.

E.1.5 Inspection

When sufficient poles are ready for inspection, they will be inspected at the point of supply by Ausgrid's Timber Inspector or deputy, of whom the *Accredited Service Provider* or their supplier will be duly notified by Ausgrid. The *Accredited Service Provider* and their supplier may be represented at all inspections and shall provide all labour and equipment necessary to move the poles for the purpose of inspection. Such inspection shall not prejudice the right of Ausgrid to reject any poles which, on delivery, are found to be defective or do not comply with this specification.

E.1.6 Rejection and Replacement

Any pole which fails to pass inspection or test, either at the supplier's works or after delivery, will be rejected.

All poles rejected in terms of this clause shall be replaced by the *Accredited Service Provider* without cost to Ausgrid, and any cost of double handling due to rejections of poles shall be met by the *Accredited Service Provider*.

E.1.7 Quality Assurance

(a) General

Suppliers of poles to *Accredited Service Providers* shall operate a certified quality system to AS/NZS 9000 series.

The objectives are to ensure that materials or equipment used on the job consistently meet Ausgrid's requirements and do not give rise to expensive field reworking, materials wastage or lost time.

The need for, and the cost of, inspecting and testing of goods received is minimised. The level of quality system must be in accordance with AS 9000 series.

(b) Quality Documentation Submission Requirements

Accredited Service Providers must ensure that they or their suppliers submit the following documentation:

- A current copy of the supplier's Quality manual unless previously supplied.
- A preliminary Quality Plan for the production of the Electrical Poles. A final Quality Plan shall be submitted and approved prior to commencement of production.
- A Statement of Conformance, or details of any area of non- conformance, with this specification.
- Where a supplier is accredited by Standards Australia or any other independent party of a copy of the Certificate of Accreditation.

E.2 PRESERVATIVE TREATED HARDWOOD POLES

The Overhead Line Supports to be supplied against this specification are as set out in Clause E.1.3 – Description of Goods, Tables 1 and 2.

E.2.1 Drawing Included In Specification

Drawing A4-21852/8 - Overhead Construction Pole Cap – Details, forms part of, and must be read in conjunction with, this part of the specification.

E.2.2 Materials and Workmanship

The timber shall be of approved species, of quality consistent with the provisions of AS 2209 Timber Poles for Overhead Lines, Section NS1 and 3 (with the exceptions or additions contained in this specification) and in every respect to the satisfaction of the Ausgrid's Timber Inspector.

(a) Approved Timbers

Wooden poles supplied shall be of the following approved timber species:

- | | |
|------------------------------|---------------------------------|
| • Broad-Leaved Red Ironbark | Eucalyptus siderophloia |
| • Grey Iron Bark | Eucalyptus paniculata northern |
| • Grey Gum | Eucalyptus punctata northern |
| • White Mahogany | Eucalyptus acmenioides northern |
| • Tallowwood | Eucalyptus microcorys northern |
| • Grey Box | Eucalyptus hemiphloia |
| • Spotted Gum | Eucalyptus maculata |
| • Narrow-Leaved Red Ironbark | Eucalyptus crebra |

Notes:

1. The maximum quantity of Spotted Gum (*Eucalyptus maculata*) allowable shall be limited to 50% for any project.
2. Blackbutt (*Eucalyptus Pilularis*), or an increased ratio of Spotted Gum, may be considered for lengths greater than 18m. The New England sub species of blackbutt is a class 3 timber and is not acceptable. Any New England subspecies poles will be rejected and must be replaced by the *Accredited Service Provider* – refer Clause E.1.6. The requirements of Clause E.1.5 that all poles for use on Ausgrid's network MUST be inspected by EA's timber inspector at the point of supply prior to delivery, and in the case of Blackbutt poles, prior to CCA treatment.

(b) Ground Line

The ground line shall be as defined in Clause D1.4.8 of AS 2209 Timber Poles for Overhead Lines.

(c) Tolerances (See also Special Poles for Transformer Installations)

All dimensions shown in Tables 1 and 2 shall include sapwood. There is no minus tolerance on ground line diameter.

However, poles with top diameter up to 30 mm less than specified, or butt diameter up to 25 mm less than specified, may be considered. The total length will be plus or minus 100 mm.

(d) Barrel & Surface Checks and End Splits

Barrel checks and end splitting in wooden poles shall be no worse than that illustrated as Number 1 rating in Figures 1.2 and 1.3 of AS 2209.

Barrel checks not more than 3 mm wide, and with a depth of 10 mm, may be permitted in Durability Rating 1 species timber. Similar width checks but with a depth of 15 mm may be permitted in Durability Rating 2 species timber.

End splits in the butt of the pole shall not exceed 500 mm in length and 5 mm in width. The butt shall, at the discretion of Ausgrid's Timber Inspector, be fitted with 125 mm x 100 mm (minimum) gang nails to prevent splitting. Also to prevent end splitting, the supplier must coat the top and butt of each pole with a brushable wax, or other approved, compound after the CCA treatment. End splits at the top of the pole will only be accepted at the discretion of Ausgrid's Timber Inspector. To avoid splitting at the top of poles, a 125 mm x 100 mm gang nail shall be fitted to the top of all poles. The fitting of gang nails to the top of all poles must take place immediately after the top of the pole is sawn off during the course of normal pre-fabrication operations.

(e) Straightness (See also Special Poles for Transformer Installations)

Wooden poles shall only be of Select Straightness as per Clause 1.54 of AS 2209. In addition, it must be possible to erect the poles in a circular hole of diameter 760 mm drilled out by a post hole borer, without further alteration to the hole.

The deviation in the diameter of the pole, when measured at the pole butt and at the ground line, shall be less than 5%.

(f) Mechanical Damage

Mechanical damage will only be allowed as described in the clauses below:

(g) Axe Marks

- (i) Across the grain - radial depth not exceeding 5 mm - but none in the critical zone.
- (ii) Parallel with the grain - depth not exceeding 5 mm and not in a continuous line.

(h) Tong and Cant-hook Punctures

Not allowable in the critical zone. Elsewhere, few and individual areas must not exceed an area equivalent to 40 mm x 40 mm.

(i) Other Mechanical Damage

Not allowable in the critical zone. Elsewhere, width not exceeding 10 percent of the circumference of the pole and not extending into the heartwood. Length shall not exceed 1 metre. After trimming areas affected by mechanical damage, the remaining sapwood of Durability Rating 2 species must not be less than 10 mm thick.

(j) Dry Side

Dry side is permitted in poles of Durability Rating 1 provided it does not occur in the critical zone, the width does not exceed 5 percent of the circumference of the pole and length is not more than 1 metre.

Dry side is not permitted in poles of Durability Rating 2.

(k) Borer Holes

All timbers susceptible to borers, especially Spotted Gum, are to be treated with a suitable insecticide as soon as practicable after cutting to prevent infestation during seasoning.

Poles with borer holes will only be accepted at the discretion of Ausgrid's Timber Inspector.

(l) Glyptotermes Holes

Any evidence of attack by Glyptotermes will lead to rejection of the pole.

(m) Critical Zone

The area between one thousand millimetres above and six hundred millimetres below the ground line.

(n) Sapwood

Sapwood shall be intact from the butt to one metre above the ground line. Only the permissible sapwood defects referred to above will be accepted elsewhere.

The minimum depth of sapwood shall be 12 mm for Durability Rating 1 species timber and 20 mm for Durability Rating 2 species timber.

(o) Trimming

All limbs and projections shall be neatly trimmed, with care being taken that no downward cuts are made in the poles. This trimming shall be carried out by means of a portable planing machine before treatment. Poles which have had large limbs, knots etc, planed off shall not be accepted - only reasonably good poles shall be selected. The tops and butts of the poles shall be sawn true and poles shall be to correct lengths.

(p) Identification

The initials "EA" and the Pole Designation shown in Tables 1 and 2 shall be legibly painted on the butt in a distinctive colour. The one colour shall be used throughout the period of the Contract.

Accredited Service Providers or their supplier shall supply and fit an identification disc in accordance with Clause 5.8 of AS 2209, by boring a hole in the side of the pole exactly 4m from the butt, then inserting and expanding the corrosion resistant disc with an appropriate punch. The layout of information proposed by the *Accredited Service Provider* shall be submitted to Ausgrid for approval prior to insertion. Discs not inserted in the correct position will be removed and relocated at the *Accredited Service Provider's* cost.

(q) Dressing

Wooden poles shall be debarked and free of mud and dirt. No checking or boring is required. All butts and tops shall be cut square. Any end coating shall be removed unless it can be shown that the coating material does not inhibit penetration of preservatives, as per Section 5.1 of AS 2209.

(r) Pole Caps

After approval by the Timber Inspector, round galvanised pole caps shall be fitted. Caps shall be supplied by the *Accredited Service Provider* or their supplier and will conform to all details of drawing A4-21852. The head of the pole shall be made circular, but must not be reduced to fit a cap. Caps shall normally be 2 to 5 mm larger in diameter than the dressed head.

Attachment of caps will be by means of 40 x 3.75 mm galvanised twisted bracket nails (Titan 'Titagrip' or similar brand approved by the Timber Inspector). Nails shall be supplied by the *Accredited Service Provider* or their supplier.

E.2.3 Preservative Treatment

Preservative treatment shall be in accordance with Section 5 of AS 2209 except as specified below.

Accredited Service Providers or their suppliers shall submit full details of the methods of impregnation and treatment together with a guarantee of durability.

(a) CCA

Preservative shall penetrate 100% of sapwood. The minimum charge retention shall not be less than 40 kg/m³ of sapwood volume for CCA salts and 25 kg/m³ for oxides. The retention in any one pole shall not be less than 30 kg/m³ of sapwood volume for CCA salts and 18 kg/m³ for oxides.

The retention of preservative in a pole shall be confirmed by chemical analysis of two plugs taken to full sapwood depth from three poles in every charge. The plugs shall be taken from opposite sides of the pole between 600mm below and 1m above the nominal ground line. The two plugs shall be combined to form one composite retention analysis sample for each pole. The sample zone for assay shall be the full sapwood depth of each plug. Analysis shall be in accordance with AS 1605 Method for sampling and analysing Timber Preservative – treated timber (Referred to in Section 5.5 of AS 2209).

The *Accredited Service Provider* shall provide two copies of all test reports carried out at an Ausgrid approved laboratory to verify the preservative retention in poles supplied. The qualification of the testing laboratory to carry out this work shall be provided, together with the limits of accuracy which are achieved.

Ausgrid may audit the test procedures. *Accredited Service Providers* must submit, or must ensure that their suppliers submit, a record of similar treatment for similar poles of the same species from the same supplier and treater, which have been carried out within three months of the time of supply and prior to the completion of the *Accredited Service Provider's* work, showing:

- (i) Date of treatment and charge number
- (ii) Contents of charge
- (iii) Number of poles
- (iv) Type and size of poles
- (v) Timber species
- (vi) Estimated total volume, treatable volume or sapwood volume in the charge
- (vii) Moisture content of poles
- (viii) Preservative and preservative concentration
- (ix) Treatment schedule:
 - o Period
 - o Temperature
 - o Vacuum
 - o Pressure
- (x) Working tank levels and temperatures at significant steps in the treatment
- (xi) Calculation of absorption and net retention, corrected for temperature

Records of each charge shall be kept by the *Accredited Service Provider's* treater. When requested by Ausgrid, a charge sheet showing the detail above shall be made available.

E.3 UNTREATED FULLY DE-SAPPED HARDWOOD POLES

The Overhead Line Supports to be supplied against this specification are as set out in Clause E.1.3 – Description of Goods, Tables 1 and 2.

E.3.1 Drawing Included In Specification

Drawing A4-21852/8, Overhead Construction Pole Cap – Details, forms part of and must be read in conjunction with this part of the specification.

E.3.2 Materials and Workmanship

The timber shall be of approved species, of quality consistent with the provisions of AS 2209, Section 1 and 2 (with the exceptions or additions contained in this specification) and in every respect to the satisfaction of Ausgrid.

(a) Approved Timbers

Untreated wooden poles supplied shall be of the following approved timber species only:

- Broad-Leaved Red Ironbark Eucalyptus siderophloia
- Grey Iron Bark Eucalyptus paniculata northern
- Grey Gum Eucalyptus punctata northern
- White Mahogany Eucalyptus acmenioides northern
- Tallowood Eucalyptus microcorys northern
- Grey Box Eucalyptus hemiphloia
- Narrow-Leaved Red Ironbark Eucalyptus crebra

(b) Ground Line

The ground line shall be as defined in Clause D1.4.8 of AS 2209.

(c) Tolerances (See also Special Poles for Transformer Installations)

There is no minus tolerance on ground line diameter. However, poles with top diameter up to 30 mm less than specified, or butt diameter up to 25 mm less than specified, may be considered. The total length will be plus or minus 150 mm.

(d) Barrel & Surface Checks and End Splits

Barrel checks and end splitting in wooden poles shall be no worse than that illustrated as Number 4 rating in Figures 1.2 and 1.3 of AS 2209.

End splits in the butt of the pole shall not exceed 500 mm in length and 5 mm in width. The butt shall, at the discretion of the appointed Timber Inspector, be fitted with 125 mm x 100 mm (minimum) gang nails to prevent splitting.

(e) Straightness (See also Special Poles for Transformer Installations)

Wooden poles shall only be of Select Straightness as per Clause 1.54 of AS 2209. In addition, it must be possible to erect the poles in a circular hole of diameter 760 mm drilled out by a post hole borer, without further alteration to the hole.

The deviation in the diameter of the pole, when measured at the pole butt and at the ground line, shall be less than 5%.

(f) Mechanical Damage

Mechanical damage will only be allowed where it does not adversely affect the appearance or strength of the pole.

(g) Dry Side

Acceptable without limit.

(h) Borer Holes

All timbers susceptible to borers are to be treated with a suitable insecticide as soon as practicable after cutting to prevent infestation during seasoning.

Poles with borer holes will only be accepted at the discretion of the Timber Inspector.

(i) Glyptotermes Holes

Any evidence of attack by Glyptotermes will lead to rejection of the pole. Treated poles may be accepted at the discretion of Ausgrid's nominated Timber Inspector.

(j) Critical Zone

The area between one thousand millimetres above and six hundred millimetres below the ground line.

(k) Sapwood and Dressing

Poles shall be de-sapped. Poles shall be octagonally dressed by approved machine processes for a length of 4.5 m from the butt. The remainder of the pole is to be "round" dressed (ie. sixteen sided). All sapwood must be removed by the dressing. All butts and tops shall be cut square.

(l) Special Poles for Transformer Installations

14 m/12 kN and 12.5 m/12 kN poles are required for use at pole transformer installations on the Ausgrid network. All 14 m/12 kN and 12.5 m/12 kN poles must have no minus tolerance on either top or butt diameter. In addition, poles must have a minimum diameter of 300 mm at 5 m from the head for a 14 m/12 kN pole, and at 4 m from the head for a 12.5 m/12 kN pole.

Only poles of exceptional straightness will be considered - AS 2209 Clause 1.5.4, Fig. 1.1 (a), 1.1 (b), 1.1 (c) and 1.1 (d) - deviations must not exceed 3L, 2L, 1L and 0.75L respectively.

(m) Identification

The initials "EA" and the Pole Designation shown in Tables 1 and 2 shall be legibly painted on the butt in a distinctive colour. The one colour shall be used throughout the period of the Contract.

Accredited Service Providers or their suppliers shall supply and fit an identification disc as according to Clause 5.8 of AS 2209, by boring a hole in the side of the pole exactly 4 m from the butt, then inserting and expanding the corrosion resistant disc with an appropriate punch. The layout of information proposed by the supplier shall be submitted to Ausgrid for approval at the commencement of the Contract. Discs not inserted in the correct position will be removed and relocated at the *Accredited Service Provider's* cost.

(n) Pole Caps

After approval by the Timber Inspector, round galvanised pole caps shall be fitted. Caps shall be supplied by the *Accredited Service Provider* or their supplier, and will conform to all details of drawing A4-21852. The head of the pole shall be made circular, but must not be reduced to fit a cap. Caps shall normally be 2 to 5 mm larger in diameter than the dressed head.

Attachment of caps will be by means of 40 x 3.75 mm galvanised twisted bracket nails (Titan 'Titagrip' or similar brand approved by the Timber Inspector). Nails shall be supplied by the *Accredited Service Provider* or their supplier.

APPENDIX F POLE STEPS, PERMANENT ATTACHMENTS AND PREVENTION OF UNAUTHORISED ACCESS

F.1 GENERAL

Installations must comply with the anti-climbing measures in the Energy Networks Association publication ENA DOC 015-2006 *National Guidelines for Prevention of Unauthorised Access to Electricity Infrastructure*, with special attention given to the presence of nearby objects, poles spaced closer than 1.5m apart, etc.

The following sections specify Ausgrid's additional requirements and restrictions on pole steps and other permanent attachments.

Permission for third party attachments to Ausgrid's poles is not implied or covered by this Appendix. This Appendix refers only to requirements and restrictions on the positioning of attachments.

F.2 POLE STEPS

With the exception of permanently installed fixed pole steps, facilities to assist climbing such as holes or plates for pole steps are not to be installed on any poles.

Poles of length 11 m or less are not normally to be fitted with pole steps. Poles of length 11 m or less which are not accessible from elevating work platforms, and which will need to be climbed (e.g. for attachment of services) may have pole steps fitted. Where pole steps are fitted, they are to be 450 mm apart, with the lowest step approximately 6000 mm above ground level, and the highest step approximately 1200 mm below the lowest mains attachment, i.e. crossarm or conductor.

For poles greater than 11 m in length, pole steps are to be installed as follows:

- **Pole mounted distribution substations** – Pole steps are to be installed in accordance with relevant drawings in NS122, or other relevant drawings.
- **11 kV link poles and link stick operated air break switch poles** – Pole steps are to be 450 mm apart, with the lowest step approximately 3600 mm above ground level, and the highest step not less than 1200 mm below the lowest high voltage crossarm or conductor.
- **11 kV down-rod operated air break switch poles** – Pole steps are not to be installed on poles which are readily accessible from elevating work platforms. On poles where climbing access is necessary, pole steps are to be installed as indicated below for 'other poles'.
- **Sub-transmission poles** – Except where indicated otherwise on line design drawings or sub-transmission pole drawings, pole steps are to be 450 mm apart, with the lowest step approximately 6000 mm above ground level.
- **Other poles** – Pole steps are to be 450 mm apart, with the lowest step approximately 6000 mm above ground level, and the highest step 1200 mm below the lowest high voltage crossarm or conductor.

The requirements specified above for pole steps may need to be varied to comply with Notes 1, 2 and 3 of Clause F.1.2.

F.3 OTHER PERMANENT ATTACHMENTS

Unless already existing prior to CIA 1139 A (dated 29/01/2001), third party attachments such as street signs, neighbourhood watch signs, meter boxes, waste bins, etc are not permitted on poles that may have to be climbed to operate equipment. This includes 11

kV link poles, link stick operated air break switch poles, low voltage link poles and distribution substation poles.

On other poles; street signs, neighbourhood watch signs and similar sign type attachments must be not less than 3 metres vertically above the ground. Poles with meter boxes or waste bins or other similar projections attached must comply with Clause (b) below.

Subject to the specific exceptions indicated below, attachments in general (including pole steps) must comply with the following minimum requirements.

A projection or device capable of providing a person with a means of ascent shall not be attached to a pole or other support forming part of an overhead line unless:

(a) the projection or device is attached to a point not less than 3 metres above the ground (measured vertically); or

(b) a minimum 2.4 m length of the pole or other support is free from any such projection or device,

and

the minimum 2.4 metre length that is free of any projection or device must not be less than 2.4 metres above the ground,

and

the minimum 2.4 metre length that is free of any projection or device must be not less than 1.2 metres below the lowest aerial conductor.

Note: In this Clause, all distances are measured vertically and ‘conductor’ includes communications cables and / or catenary wires.”

The diagram below illustrates the requirements of Clauses (a) and (b).

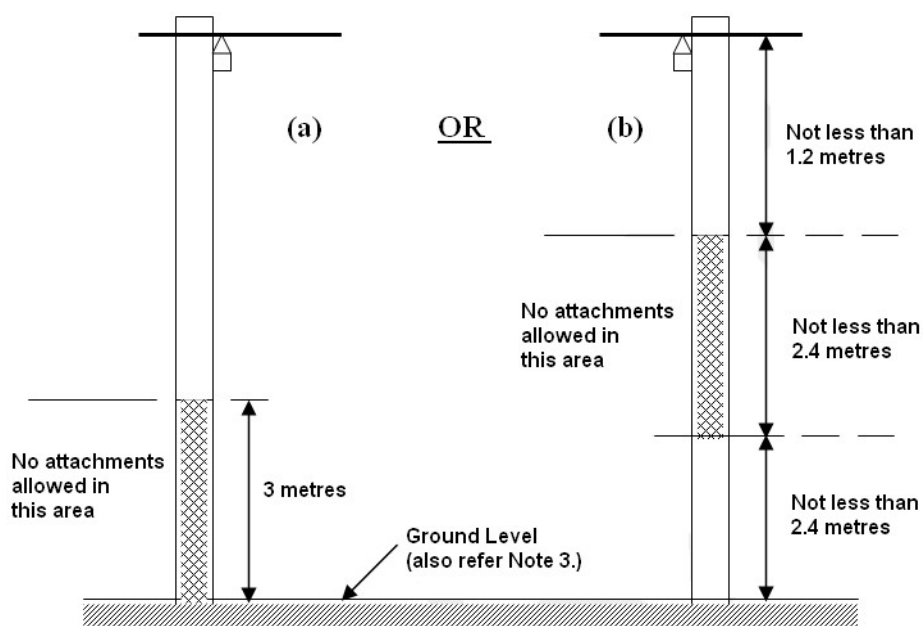

Exceptions:

- (i) A projection or device may be attached within the zones indicated in Clauses (a) or (b) if the pole or support is fitted with an approved guard preventing climbing.
- (ii) Operating handles and rods of approved air break switch installations and approved locked collapsible ladders that are not capable of providing a means of ascent, may be attached within the zones indicated in Clauses (a) or (b).

In Exceptions (i) and (ii), ‘approved’ means approved by the Manager – Network Assets.

Notes:

1. Combinations of attachments, including combinations of pole steps and other attachments, must comply with the above requirements.
2. Relocation or removal of attachments may be necessary to ensure continuing compliance with Clause (a) or (b). eg; the attachment of a communications cable may necessitate relocation of other attachments.
3. Where poles are located close to structures, street signs, awnings, telephone boxes, rockwalls or similar elevated objects which could reasonably provide a means of access to part of the pole above normal ground level, the requirements of Clause (b) apply, with the nominal ground level then being the highest elevated reasonable point of access.

APPENDIX G LASHING CONDEMNED POLES USING POLYPROPYLENE ROPE

The lashing of condemned poles using polypropylene rope is one of the approved methods for supporting a condemned pole to make it safe.

CAUTION

Condemned poles lashed with polypropylene rope are not to be worked on and should be replaced as soon as practicable.

Lash condemned poles using polypropylene rope as follows:

1. Cut the rope to the correct length and burn the ends or use the thumb knots to stop fraying.

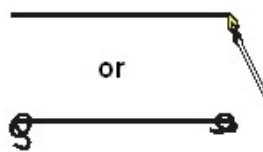

2. Tie the rope to the new pole 4 metres above ground using a clove hitch and two half hitches.

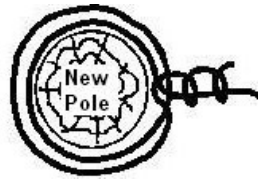

3. Wrap the standing part of the rope around the poles as shown (minimum of two full turns around the old pole, and always finish on the new pole).

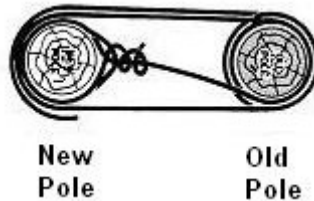

4. Tie the tail of the rope with a clove hitch as shown.

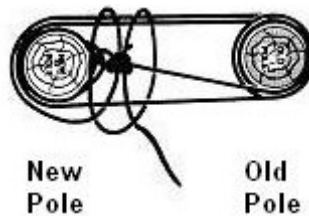

5. Tighten the clove hitch but do not stress the poles. Finally lock the tail of the rope with a half hitch as shown.

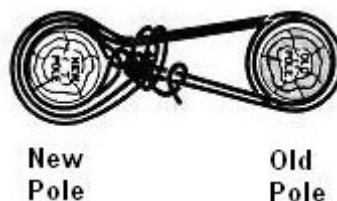

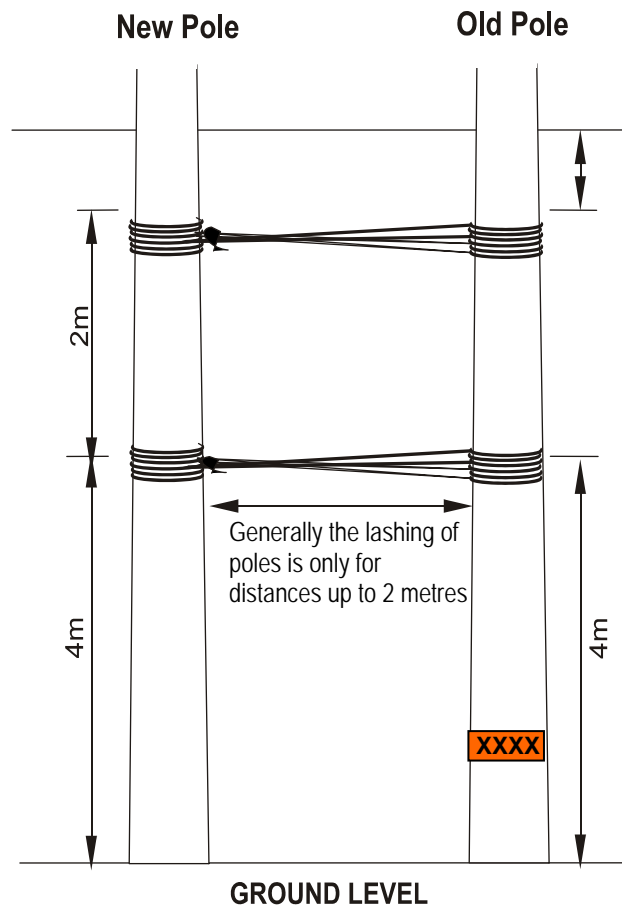

Note: To “make safe” condemned poles the use of stays and pikes may be needed in conjunction with pole lashings.

The old pole can be secured by either one or a combination of methods described in Section 12.

APPENDIX H “MAKING SAFE” CONDEMNED POLES USING PIKES

The “making safe” of a condemned pole using pikes is only to be used when methods of securing condemned poles in Section 12 can not be used. A documented risk assessment is to be completed when using pikes which considers:

- public safety;
- the risk of interference to the pikes;
- stability at the head of the pole and at the ground line;
- the load on the pole;
- the position of the defective section of the pole;
- the height of the pole;
- positioning of the pikes; and
- stability of the ground.

Pikes must be fixed to the pole and secured to ensure the pole doesn't move or twist under load. Appropriate steps must be taken to ensure the pikes can perform their intended use. Steps could include but are not limited to, tying the pike's spikes to the pole, tying/choking the pikes at groundline.

Note: These condemned poles should be replaced as soon as practicable.

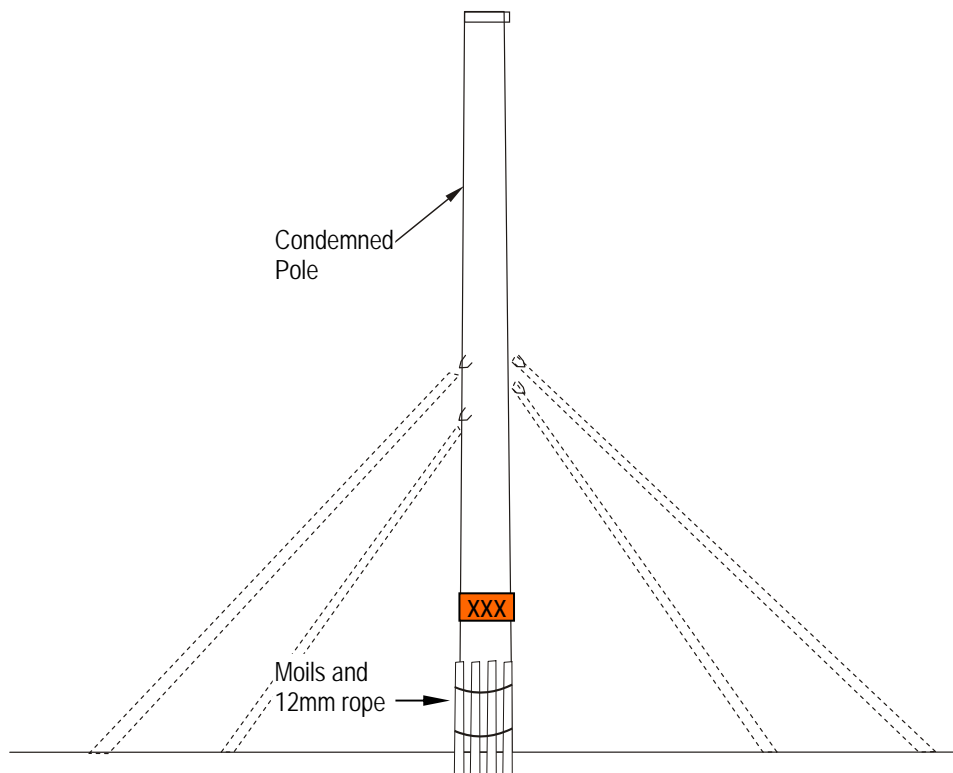

Typically moils are driven a minimum 350mm below groundline

Sufficient pikes must be used in appropriately positions to ensure the stability of the pole. When required the base of the pole should be stabilised with such items as moils. Moils may take the form of star stakes or any other robust metal rods used in sufficient numbers (minimum 3) and lashed to the pole with rope. The depth of the moils will

depend on the bearing strength of the soil and the moil is typically driven into the ground a minimum of 350 mm. The strength of the soil can be assessed while performing the below ground pole inspection as per NS146 *Safe Inspection Procedure for Working on Poles*. The depth of the moils should be deeper than 350mm in poor bearing strength soils.

The risk assessment process used in “making safe” condemned poles should identify the most appropriated hazard risk controls to achieve the safest result for each individual condition and location. The on-site staff are required to perform the risk assessment and then identify the best method or combination of methods to ensure the safest outcome is achieved.

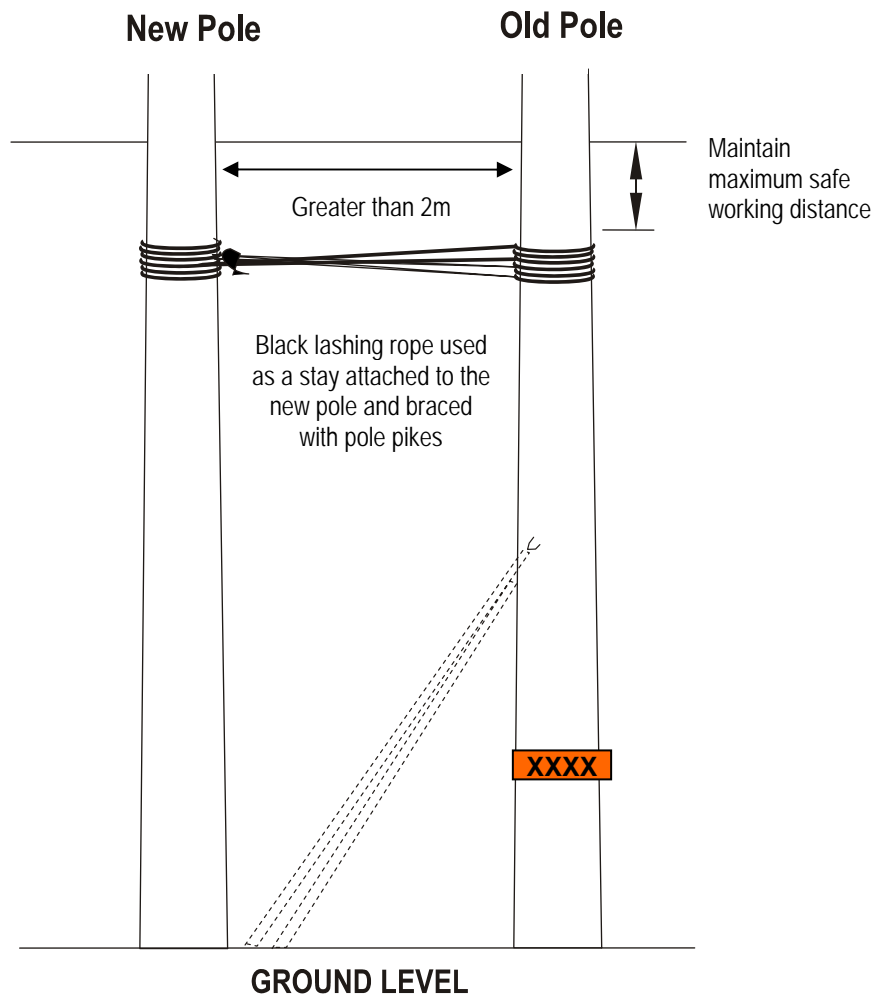

The above pole is secured using a combination of a stay and two pole pikes. Different combinations using stays, lashings, pikes & moils can be utilised to achieve the safest result (eg all stays, two stays and a number of pikes etc).



© Ausgrid.

This document must not be reproduced in whole or in part or converted to machine readable form or stored in a computer or imaging system without the written permission of Ausgrid.

Revision History

Initial issue:

February 1998

This issue:

December 2008

Document Control

Authorised By: Terry Lampard

Date: 15 December 2008

Manager – Standards & Communications

Document Number:

NS128