



Network Standard Advice

No. 1606

21/3/2011

Doc. Ref. Network Standard NS177 (January 2010)
and NSA1588.

TO: Customers, Service Providers and Ausgrid Staff.

Amendments to Ausgrid's Network Standard NS 177 11kV Joints (Including Transition Joints) and Terminations – Polymeric Insulated Cables, January 2010

Introduction

This Network Standard Advice (NSA) amends Network Standard (NS) 177 11kV Joints (Including Transition Joints) and Terminations – Polymeric Insulated Cables, which will be updated in due course.

These amendments are:

- Table 6.5 has a new stockcode for 35mm² bimetal lugs.
- New Clause 6.4 Clamping Method of 11kV Cables in L Kiosks
- Clause 6.5 Stainless Steel Bolts and Set-screws – Lubrication of Threads - replace clause.
- New Clause 6.10 Pre-made Transformer Leads for Kiosks.
- New Clause 6.15 Cable Termination for Hazemeyer Switchgear (HV1-55).
- Clause 7.2 Installation instruction reference updated.
- Clause 8 Inclusion of 500mm² three core straight joints utilising mechanical core connectors.
- Clause 9 Inclusion of three-to-one joints to suit Triplex Cables utilising mechanical core connectors.
- Clause 10.3 Installation instruction reference updated.
- Clause 13.3 Installation instruction reference updated.

Note: Current network standards, with NSAs and CIAs, are available on Ausgrid's Internet site at www.ausgrid.com.au.

Amendments

Page 15, Clause 6.4

In Table 6-5, replace the existing stockcode for the 35mm² bimetal crimp lug with the following stockcode:

Cable Size and Type	Stockcode Indoor Lugs	Stockcode Outdoor Lugs
35 mm ² Aluminium	H109553	H109553

Page 15, Clause 6.4

New Clause 6.4, renumber Clauses 6.4 to 6.19 as Clause 6.5 to 6.20 respectively.

6.4 Clamping of 11kV Polymeric Insulated Cables in L Kiosks

The following figures and associated table show the method for clamping 11kV polymeric insulated cables in L kiosks.

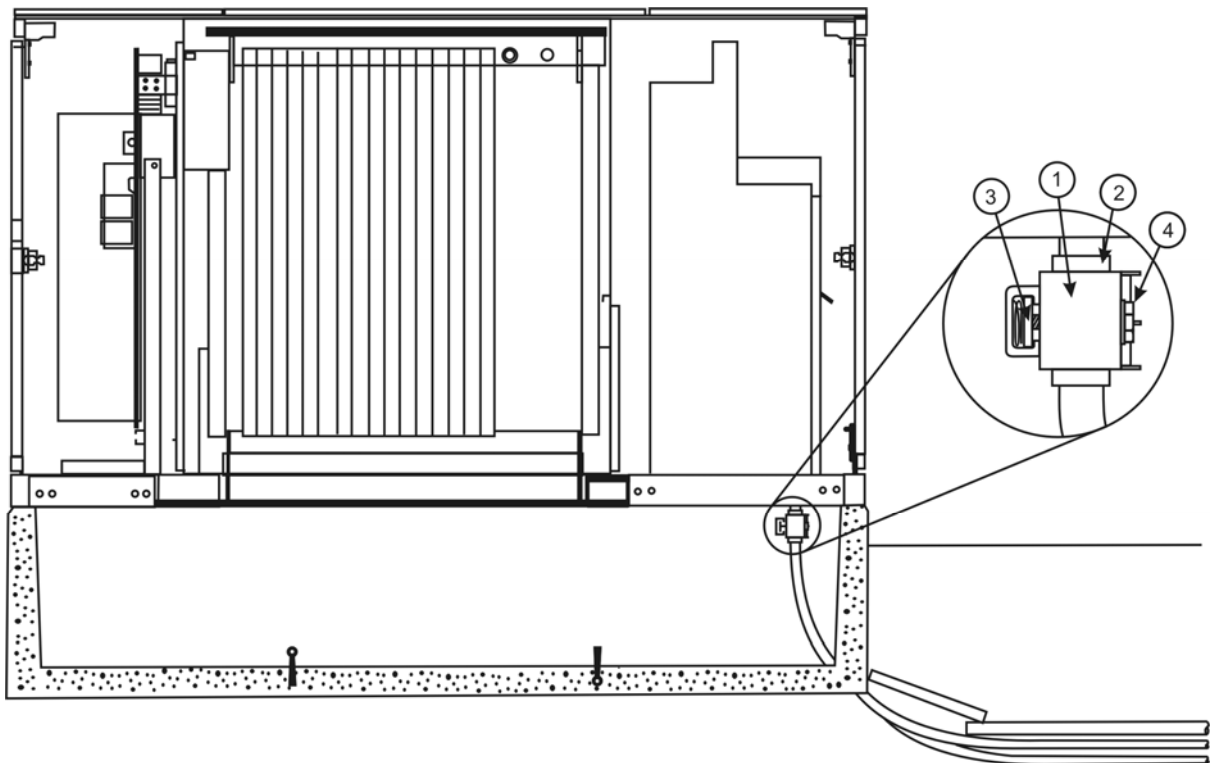

Figure 6-7 - Cable Clamping Detail (side view)

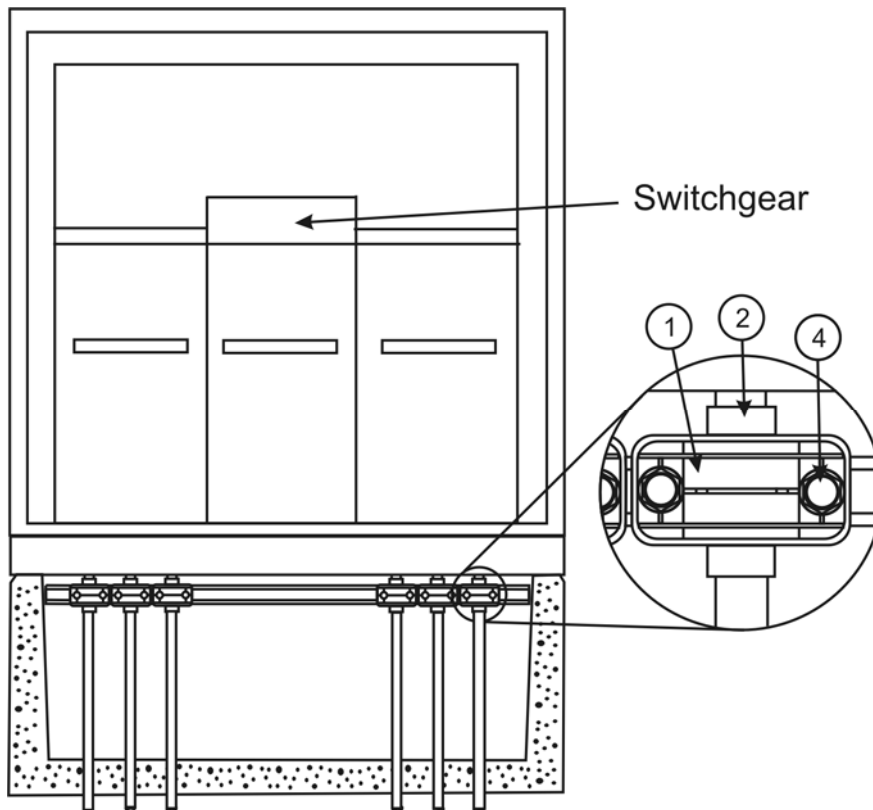

Figure 6-8 Cable Clamping Detail (front view)

Table 6-5 – Items required to Clamp one set of Cable Terminations

Item	Description	Qty	Stockcode
1	Cable clamp suitable for either: <ul style="list-style-type: none"> • 95-185 mm² cable, or • 300 mm² cable 	3 3	180291 180350
2	Nitrile rubber liner	1 Cut to length from 300mm strip	179201
3	Spring-loaded nut	6	Unistrut Part No. P4010
4	Stainless steel screw M12 x 65mm	6	157099

Page 16, Clause 6.5:

Replace the paragraph with the following

Before installation of each stainless steel bolt or set-screw, the thread shall be lubricated with specially formulated anti-seize grease containing nickel which is available on Ausgrid stockcode 177212. Equivalent anti-seize grease containing nickel may be used but must be submitted to Ausgrid for approval first. Care shall be exercised to prevent the anti-seize grease from contaminating the interface of the electrical contact surfaces. Any excess of anti-seize grease shall be removed using a clean dry cloth after the bolt or set-screw has been installed.

Page 22, Clause 6.9:

Replace Figure 6.9 with the figure below.

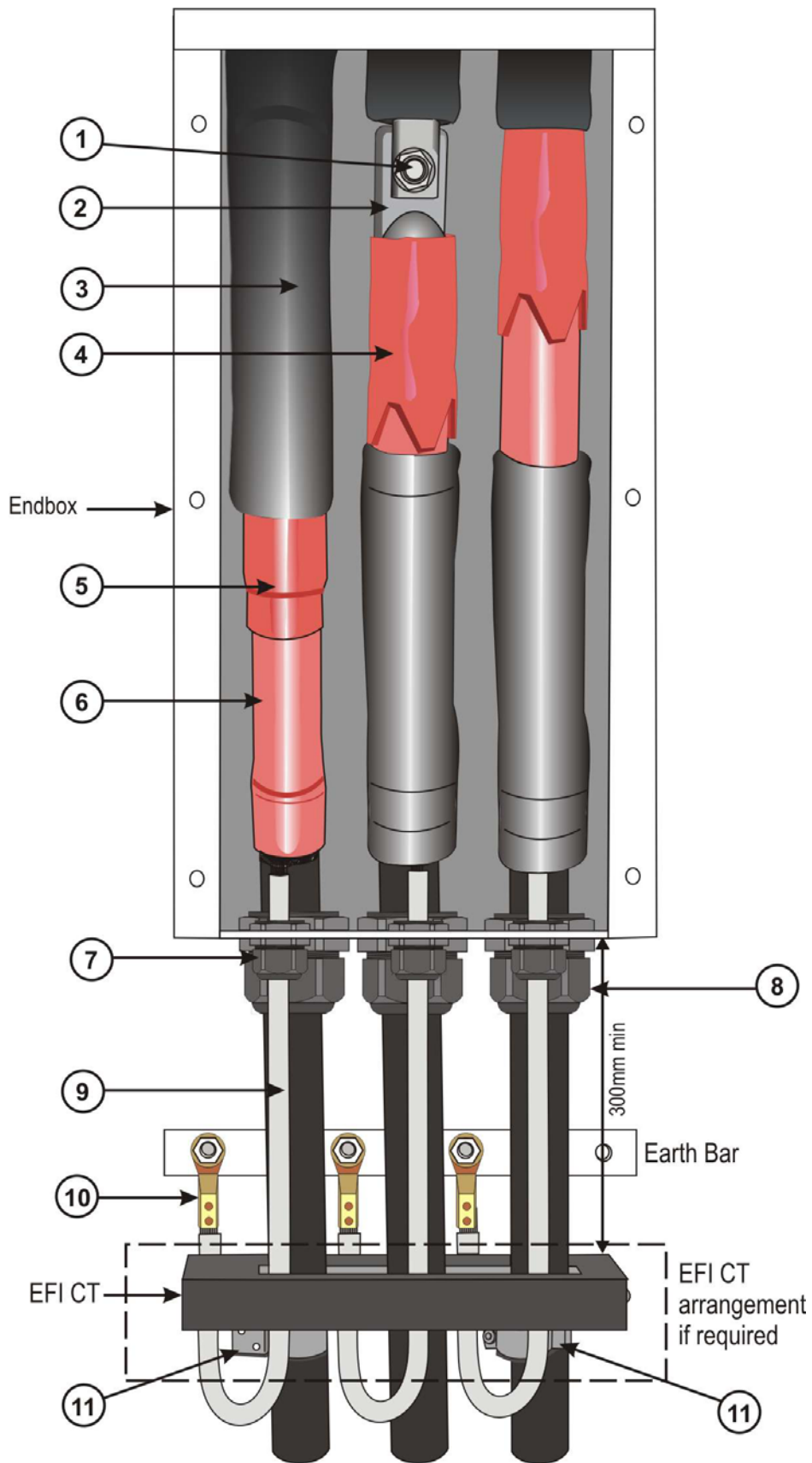

Page 22, Clause 6.10:

New Clause 6.10, renumber Clauses 6.10 to 6.19 as Clause 6.11 to 6.20 respectively.

6.10 Pre-made Transformer Leads for Kiosks

The following pre-made transformer leads for kiosks are 3metres long and are supplied with a cable gland fitted at the heatshrink cable termination end of the lead which has the screen wire lead. They are available for use in situations where the existing transformer leads require replacing:

- Heatshrink cable termination and compression lug suitable for M12 stud at one end and a RTE load break separable connector at the other end (stockcode 147959).
- Heatshrink cable termination and compression lug suitable for M12 stud at one end and a 200A load break separable connector at the other end (stockcode 180081).
- Heatshrink cable termination and compression lug suitable for M12 stud at both ends (stockcode 179878).

6.15 Cable Termination for Hazemeyer Switchgear (HV1-55)

This specification provides the requirements for terminating 185mm² single-core polymeric insulated wire screened cables and 35mm² single core polymeric insulated transformer leads into Hazemeyer Switchgear.

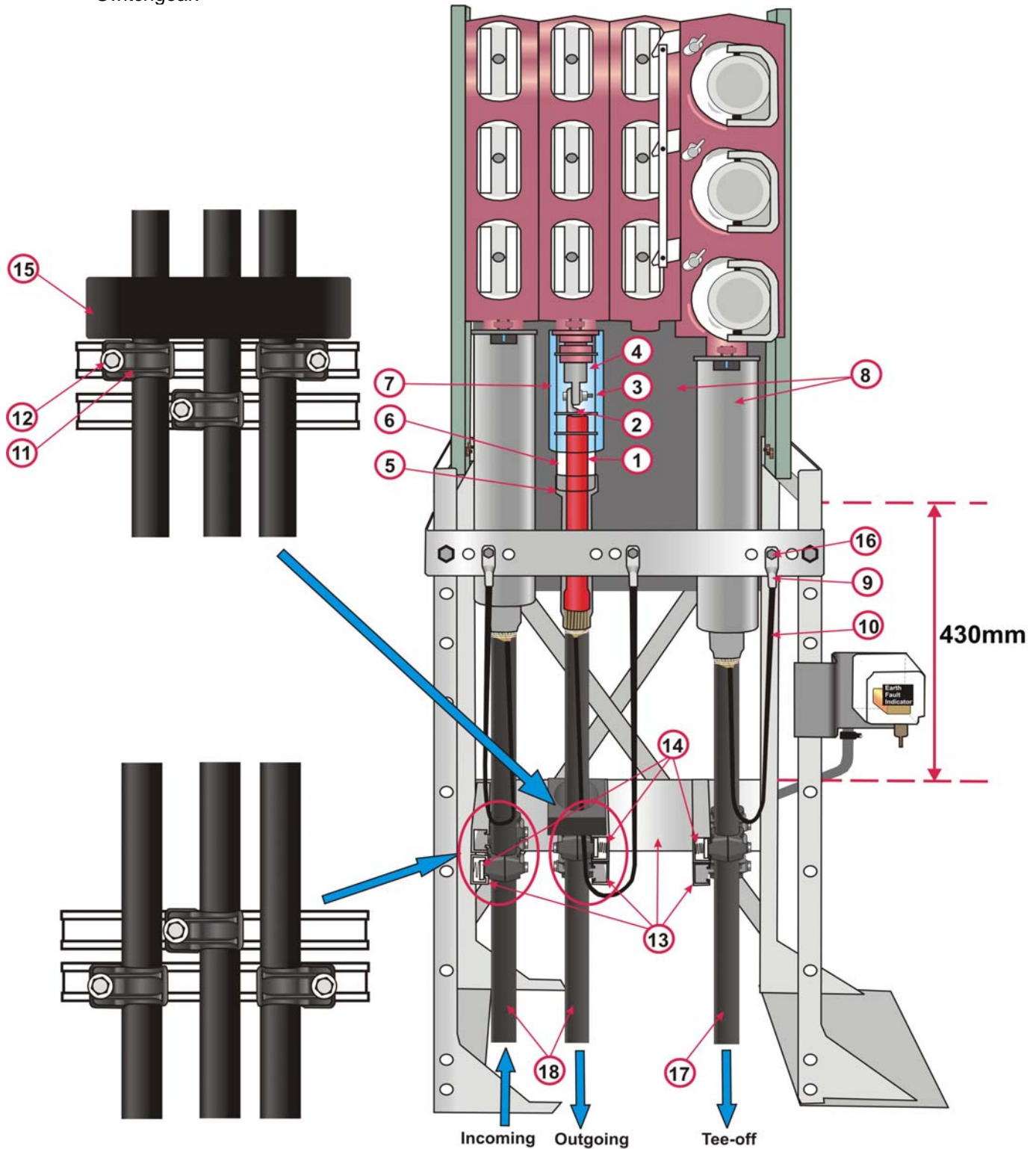

Note: Only one cable per module shown for clarity.

Figure 6-19 – Indoor Cable Termination into Hazemeyer Switchgear

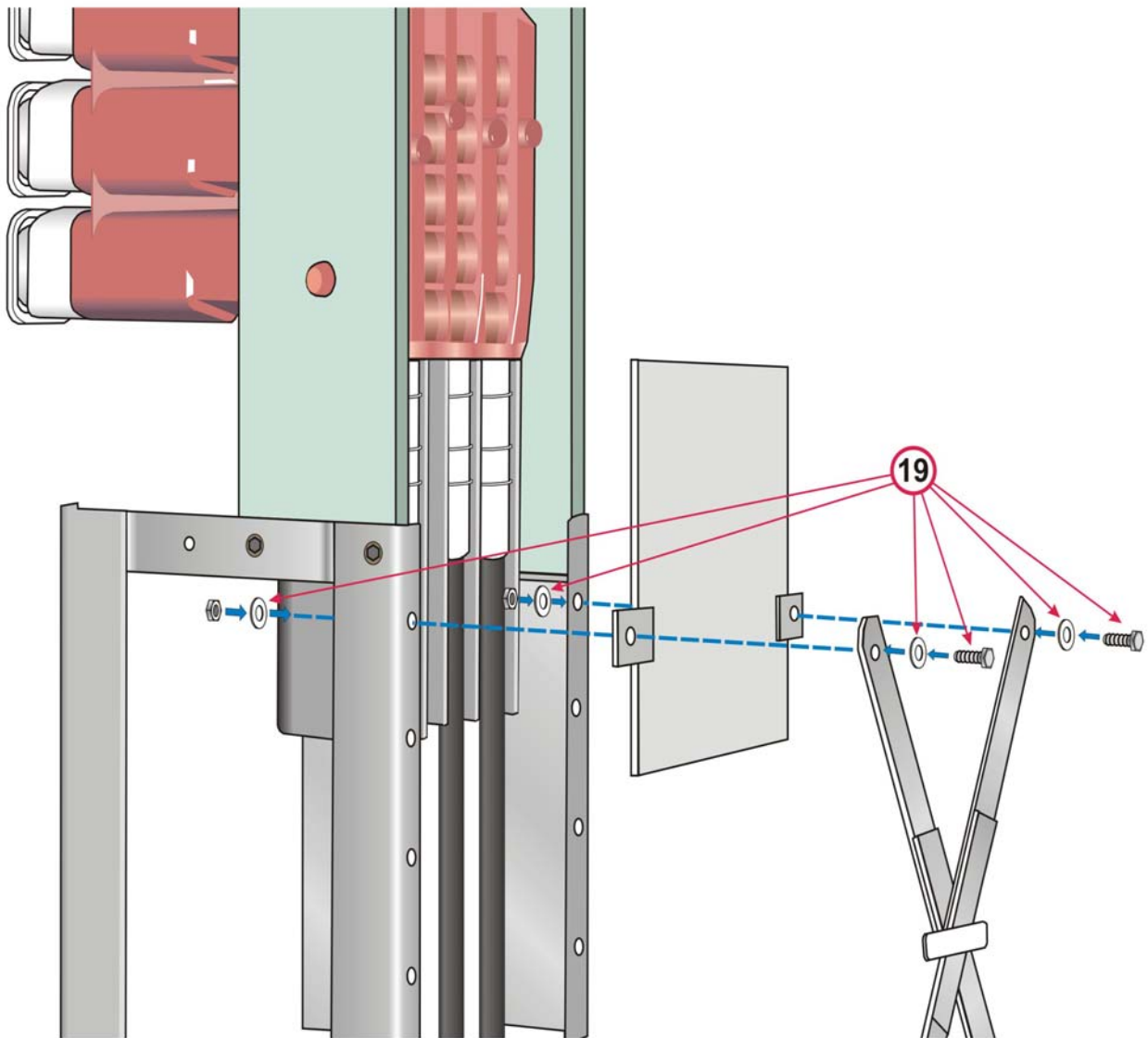

Figure 6-20 – Installation of the rear barrier using M5 × 25mm set screws and M5 flat washer

Table 6-15 - Material List for Indoor Cable Termination into Hazemeyer Switchgear (The following material will be sufficient to complete one set of cable termination)

Item	Description	Qty	Stockcode
1	Termination kit	3	177792
2	Phase core lug	3	175532 and note 2 below
3	Hex head screw M12 x32, Belleville Washer M12, Hex Nut M12	3	See note 1 below
4	Connector Adaptor	3	See note 1 below
5	Coldshrink seal	3	See note 1 below
6	Insulating tube	3	See note 1 below
7	Retainer half for tube	2	See note 1 below
8	Grey cable barrier and rear barrier	1	180222
9	Screen wire lugs	3	177741
10	Screen wire re-jacketing tubing	Cut length from 40m roll	177751
11	Cable Clamp: 185mm ² feeder cable Transformer cable	3 3	181882 181883
12	M10 x 60mm set screw and M10 flat washer	3	Buy-in
13	Cable support bracket	1	181913
14	Spring –loaded Nut	3	Unitstrut Part No.4008
15	EFI if required	1	
16	M12x30mm stainless steel bolt, M12 stainless steel nut, 2xM12 stainless steel flat washers, M12 stainless steel spring washer	3	175911
17	Pre-made transformer leads	1	Clause 6.10
18	11kV 185mm ² single-core polymeric insulated wire screened cables	As Required	177567
19	M5 x 25mm set screws and M5 flat washer	2	Buy-in

Note:

1. Cable termination connection kit is available on stockcode 181881. The cable connection must be constructed in accordance with the installation instructions supplied with the kit.
2. The palm width of the lug shall not exceed 36mm.

Page 53, Clause 7.2:

Replace the third dot point with the following:

- The joints listed in Table 7-1 shall be constructed in accordance with the Tyco Electronics installation instruction ESD-3244-AU-3/10, with the exception of the 300 mm² single core cables with 150 mm² screen wires which shall be constructed in accordance with the Tyco Electronics installation instruction ESD-4820-AU-5/09. Both installation instructions are supplied in the joint kit. Joints for 630 mm² and 1000 mm² cables (see Table 7-1A) shall be constructed in accordance with Tyco Electronics installation instruction ESD-3248-AU-7/02 supplied in the joint kit.

Page 54, Table 8-1:

Add the details for the 500mm² Straight Through Joint.

Three Core Cable Sizes		Stockcode No.
500 mm ² Al or Cu	300 mm ² Al	181962
500 mm ² Al or Cu	400 mm ² Al	181962
500 mm ² Al or Cu	500 mm ² Al or Cu	181961

Cable Range	Tyco Kit Number	Stockcode No.
500mm ² to 400mm ² or 300mm ² Aluminium 500mm ² to 400mm ² or 300mm ² Copper	MXSU-SY207	181962
500mm ² to 500mm ² Aluminium 500mm ² to 500mm ² Copper	MXSU-SY208	181961

Page 54, Table 8-2:

Delete Table 8-2 and associated notes.

Page 55, Clause 8.1:

Replace Clause 8.1 with the following:

Core connectors and screen wire connectors are of the mechanical type and are included in the joint kit.

The connectors shall be installed strictly in accordance with the manufacturer's installation instructions.

Ausgrid will not accept substitutes for the connectors unless specific approval has been obtained.

Installed core connectors shall maintain the load and short circuit current carrying capacity of the jointed cores and the screen wire connectors shall maintain the fault current carrying capacity of the cable's screen wires.

Page 55, Table 8-3:

Delete Table 8-3.

Page 55, Clause 8.2:

Replace the third dot point with the following:

- Joints shall be constructed in accordance with the Tyco Electronics installation instruction ESD-3245-AU-2/11, except for MXSU-SY207 joint kits which shall be constructed in accordance with the Tyco Electronics installation instruction ESD-5339-AU-3/10. The installation instructions are supplied in the joint kits.

Add the following new dot point:

- Joint kit EPKJ-SY129 with installation instruction ESD-3247-AU-7/02 can continue to be used until stocks are depleted.

Page 57, Table 9-1:

Add the details for the Triplex Three-to-One Joints.

Three-to-One Joint		Stockcode No.
from three core	to single core	
185 mm ² Al	185 mm ² Cu (Triplex)	181965
185 mm ² Al	300 mm ² Cu (Triplex)	181965
300 mm ² Al	185 mm ² Cu (Triplex)	181965
300 mm ² Al	300 mm ² Cu (Triplex)	181965
400 mm ² Al	185 mm ² Cu (Triplex)	181965
400 mm ² Al	300 mm ² Cu (Triplex)	181965
500 mm ² Al or Cu	185 mm ² Cu (Triplex)	181966
500 mm ² Al or Cu	300 mm ² Cu (Triplex)	181966

Triplex cables are single core cables with a 70mm² copper wire screen and the cables are bundled together.

Cable Range	Tyco Kit Number	Stockcode No.
185mm ² to 400mm ² Aluminium 185mm ² to 300mm ² Copper	MXSU-SY210	181965
500mm ² Aluminium or Copper to 185mm ² - 300mm ² Copper	MXSU-SY206	181966

Add the details for the 300mm² Single Core Cable with 150mm² copper wire screens.

Three-to-One Joint		Stockcode No.
from three core	to single core	
300 mm ² Al	300 mm ² Cu (150 mm ² screen wires)	181963
400 mm ² Al	300 mm ² Cu (150 mm ² screen wires)	181963
500 mm ² Al or Cu	300 mm ² Cu (150 mm ² screen wires)	181964

Cable Range	Tyco Kit Number	Stockcode No.
300mm ² - 400mm ² Aluminium 300mm ² Copper (150mm ² screen wires)	MXSU-SY212	181963
500mm ² Aluminium or Copper to 300mm ² Copper (150mm ² screen wires)	MXSU-SY211	181964

Page 57, Table 9-1A:

Delete Table 9-1A and associated notes.

Page 58, Clause 9.1:

Replace Clause 9.1 with the following:

Core connectors and screen wire connectors are of the mechanical type and are included in the joint kit.

The connectors shall be installed strictly in accordance with the manufacturer's installation instructions.

Ausgrid will not accept substitutes for the connectors unless specific approval has been obtained.

Installed core connectors shall maintain the load and short circuit current carrying capacity of the jointed cores and the screen wire connectors shall maintain the fault current carrying capacity of the cable's screen wires.

Page 58, Table 9-2:

Delete Table 9-2.

Page 59, Clause 9.2:

Replace the third dot point with the following:

- Joints shall be constructed in accordance with the Tyco Electronics installation instruction: ESD-5407-AU-10/10 for 185mm², 300mm² or 400mm² three core cables to triplex cables; ESD-5340-AU-9/10 for 500mm² three core cables to triplex cables; ESD-5589-AU-10/10 for three core cables to single core cables with 150mm² screen wires.

Add the following new dot point:

- Joint kit EPKJ-SY129 with installation instruction ESD-3405-AU-9/08, and joint kit EPKJ-SY194 with installation instruction ESD-4748-AU-5/08 can continue to be used until stocks are depleted.

Page 61, Clause 10.3:

Replace the second dot point with the following:

- The joint shall be constructed in accordance with the installation instruction (ESD-3290-AU-3/10 for Tyco kits) supplied in the joint kit.

Page 69, Clause 13.3:

Replace the second dot point with the following:

- Joints from 0.06 inch² (39 mm²) three core PILC cables to 185 mm² single core polymeric cables shall be constructed in accordance with the Tyco Electronics installation instruction ESD-4506-AU-10/10 supplied in the joint kit. All other joints shall be constructed in accordance with the Tyco Electronics installation instruction ESD-3271-AU-9/10 supplied in the joint kit.

Page 72, Table 15-1:

Replace the table heading with the following:

Table 15-1 Table 15-1 – Polymeric Cold Pour Resin Tee Joint Kits and Stub Tee Joint Kits

Walter Stefani
Executive Manager – Logistics and Distribution Engineering