

No.	DESCRIPTION	STOCK	QTY	
			ARR-1	ARR-2
1	CONNECTOR - SPLICE IPC 6-25 AL/CU INSULATED (HSC)	H109686	2	2
2	CLAMP - CABLE STRAIN 2-4 CORE 6-25mm <sup>2</sup>	H102491	1	1
3	CABLE - 4x25mm <sup>2</sup> AL ABC XLPE, 4 CORE	H109280	A/R	A/R
4	EYENUT - M12, EXTENDED, GALVANISED	H39281	1	-
	HOOK - Q TYPE, EXTENDED, DRG : 177807/1	128934	-	1
5	WASHER - SQUARE 50x50x6mm Ø16 HOLE GALVANISED	175563	1	-
6	NUT - M12 GALVANISED	9118	2	-
7	END CAP - 25mm <sup>2</sup> PUSH ON	H109447	1	1
8	CABLE TIE	TBA	1	1
9	BOLT - M12, GALVANISED, LENGTH TO SUIT	-	-	1
10	WASHER - FLAT, M12, GALVANISED	177982	-	1
11	CONSUMER MAINS		1	1
12	CONNECTOR - SPLICE FOR NEUTRAL PHASE, 6-25 Al/Cu INSULATED SERVICE	182906	1	1

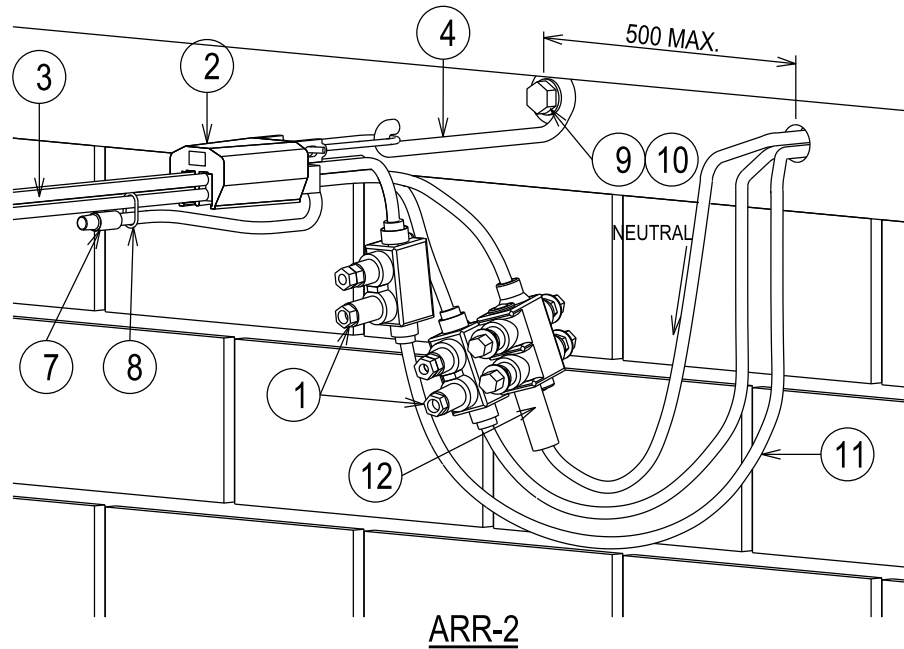
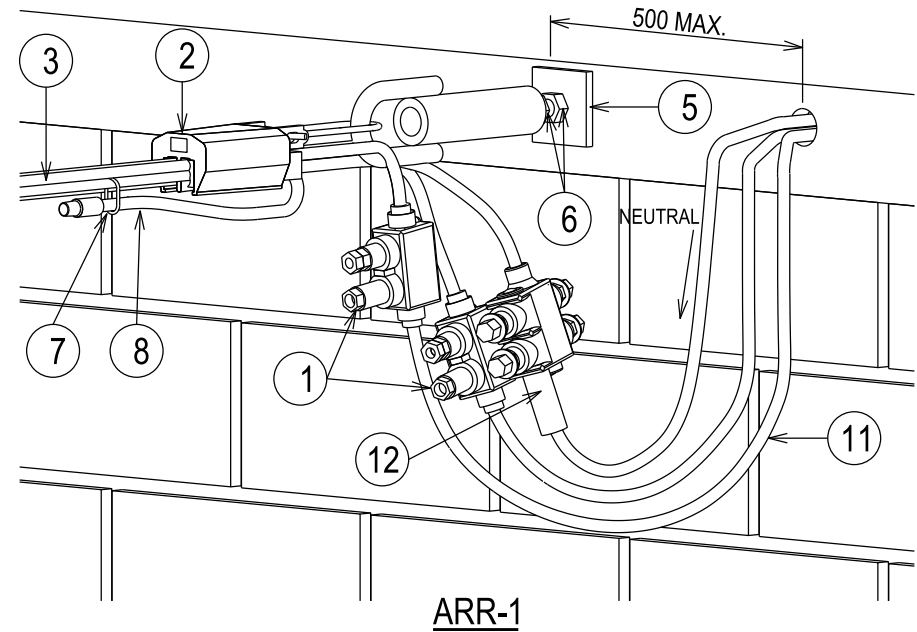

CAD DRAWING  
DO NOT MANUALLY AMEND  
AMENDMENTS

DWN: PATRICIA RIOS  
CHKD: HIRI EHAMPARAM  
DATE: 05/05/2014  
NEUTRAL CONNECTION  
CHANGED, MATERIAL  
LIST AMENDED.

APPD: MATTHEW CUPPLES

NETWORK STANDARD  
**Ausgrid**  
145 NEWCASTLE RD  
WALLSEND NSW 2287  
PHONE: 4951 9388  
FAX: 4591 9389

DESIGNED	ROBERT KNOWLES
DRAWN	PATRICIA RIOS
CHECKED	ROBERT KNOWLES
AUTHORISED	GREG SKINNER
DATE	02/07/04
SCALE	NTS
MAP REF.	
LGA	

STANDARD CONSTRUCTION  
100AMP HOUSE SERVICE CONNECTION  
2 PHASE - BARGE BOARD

PROJECT No.	NET-STD
PROJTRAK No.	-
Sheet 01 of 1 Sheets	
A4	152499
	4