

No.	DESCRIPTION	STOCK	QTY
1	CABLE - 4x95mm ² AL ABC XLPE	67959	A/R
2	CLAMP - CABLE STRAIN 4 CORE 95mm ² XLPE	176652	2
3	EYELUG - 95mm ² ABC	58743	8
4	EYELUG - CUSTOMER CABLE	58743	4
5	BOLT - M12x35mm, HEX, STAINLESS STEEL	45021	4
6	WASHER - M12, FLAT, STAINLESS STEEL	49429	8
7	WASHER - M12, SPRING, STAINLESS STEEL	143859	4
8	HEATSHRINK - 2 TO 1 GLOVE KIT	90324	4
9	BOLT - M16, LENGTH TO SUIT	N/A	2
10	BRACKET - TERMINATION, RIGHT ANGLE GALVANISED	66571	2
11	STRUT/BACKET (AS PER SERVICE & INSTALLATION RULES OF NSW	N/A	1
12	CONSUMER MAINS	-	1

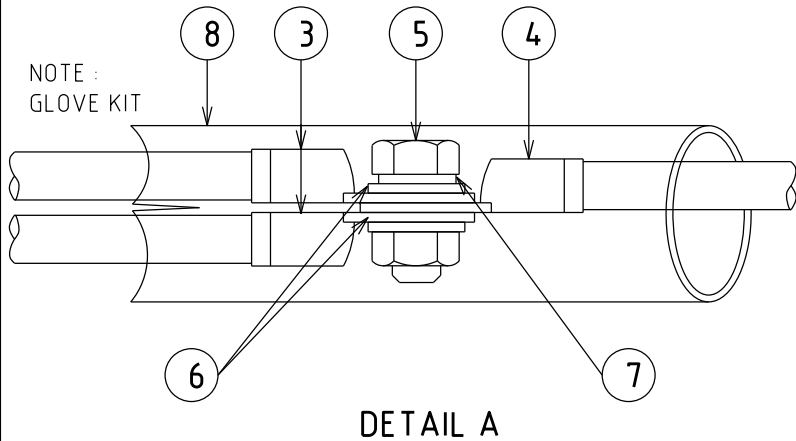
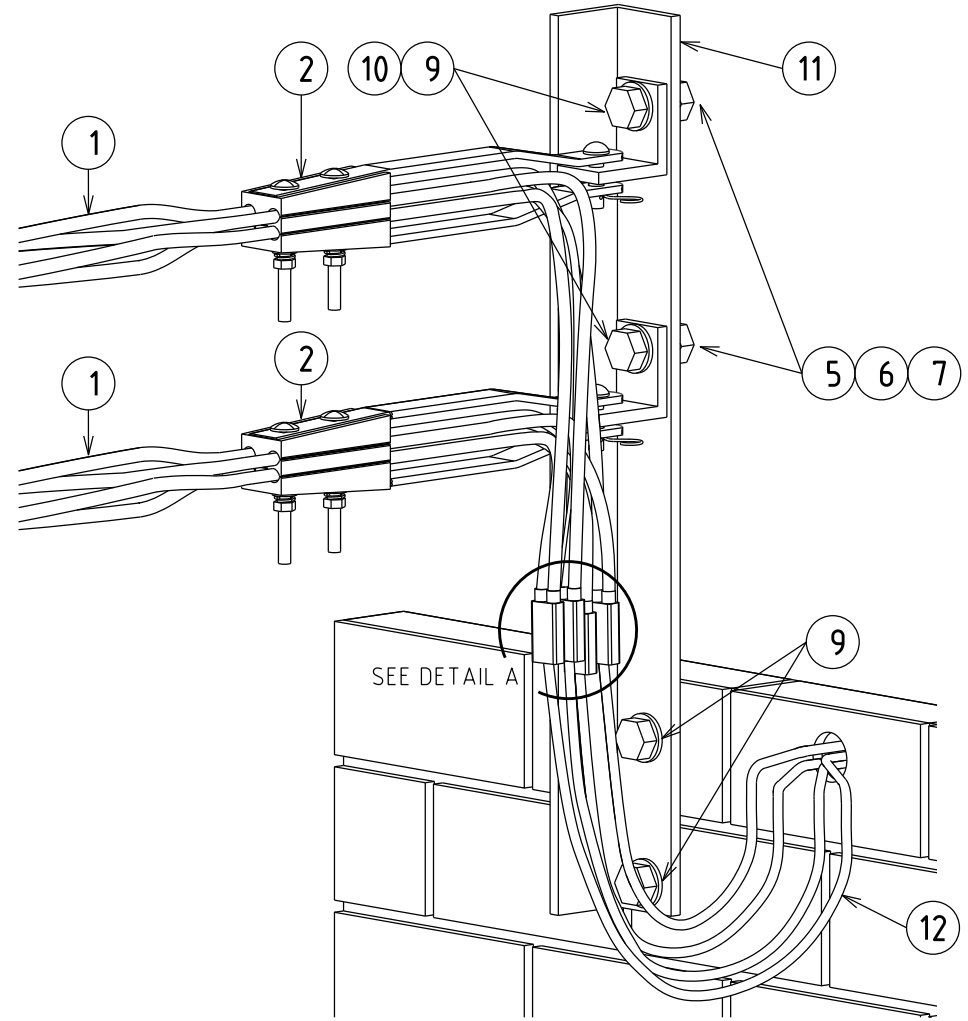

CAD DRAWING DO NOT MANUALLY AMEND AMENDMENTS	DWN: PATRICIA RIOS	APP'D: BRETT GRENFELL
	CHKD: JOHN VINCENT	
2	DATE: 29/05/2008 TABLE AMENDED.	DWN: GARRY CRAIG
3	DATE: 11/11/2013 AUSGRID BORDER APPLIED.	CHKD: GARRY CRAIG
		APP'D: GRANT BAILEY

NETWORK STANDARD
Ausgrid
145 NEWCASTLE RD
WALLSEND NSW 2287
PHONE: 4951 9388
FAX: 4591 9389

DESIGNED	ROBERT KNOWLES
DRAWN	PATRICIA RIOS
CHECKED	ROBERT KNOWLES
AUTHORISED	GREG SKINNER
DATE	02/07/04
SCALE	NTS
MAP REF.	
LGA	

STANDARD CONSTRUCTION
400AMP 3 PHASE
SERVICE CONNECTION
BRACKET/STRUT

PROJECT No.	NET-STD
PROJTRAK No.	-
Sheet 01 of 1 Sheets	
A4	162007
	3